



BRIGHT SOLAR
SOLUTIONS

APsmart Rapid Shutdown Solution Technical Training

for  Inverters

RSD-S-PLC Installation, commission and application

Step 1: RSD-S-PLC Mounting

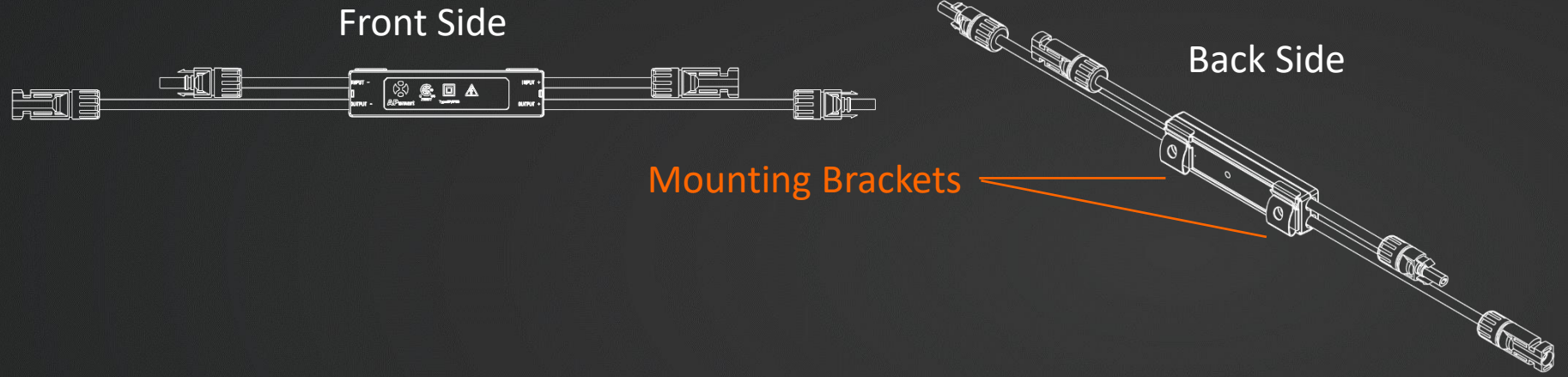

Method 1: Clip the RSD-S-PLC facing out on the outside of the module frame. (Recommend)

Method 2: Clip the RSD-S-PLC facing the back of the module under the lip of the module frame

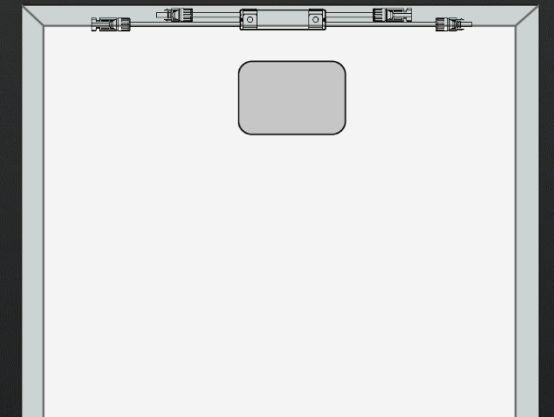
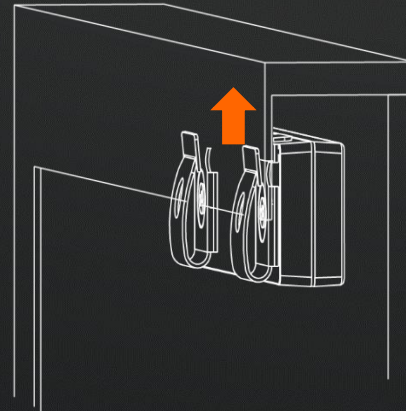
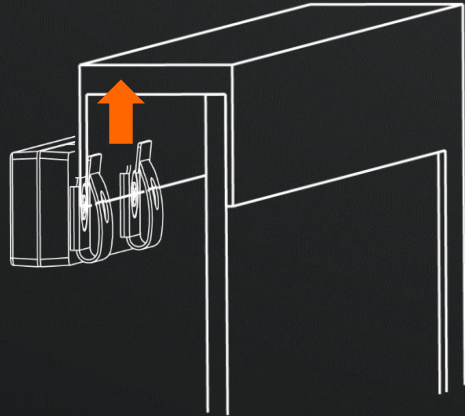
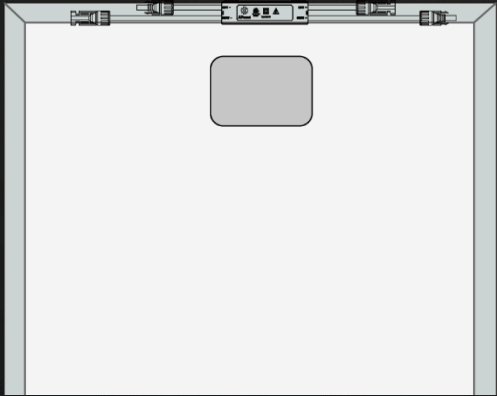

RSD-S-PLC outputs a DC voltage of **0v** when out of box.

Step 1: RSD-S-PLC Mounting

Step 2: Connect With PV Module

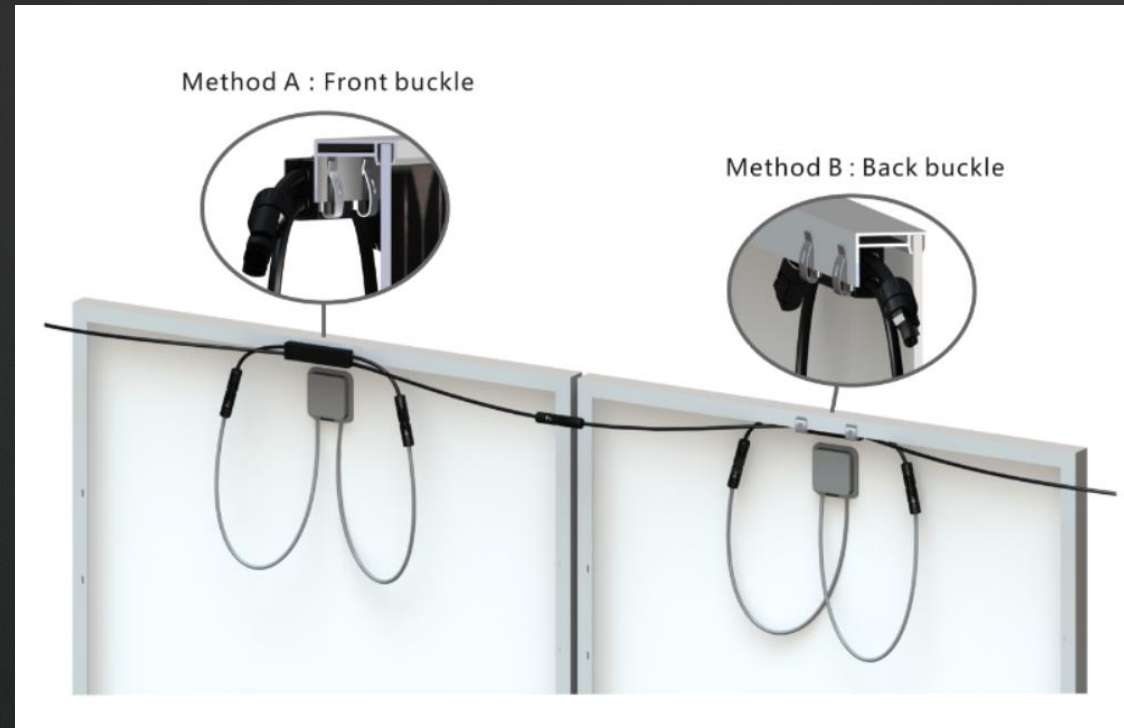
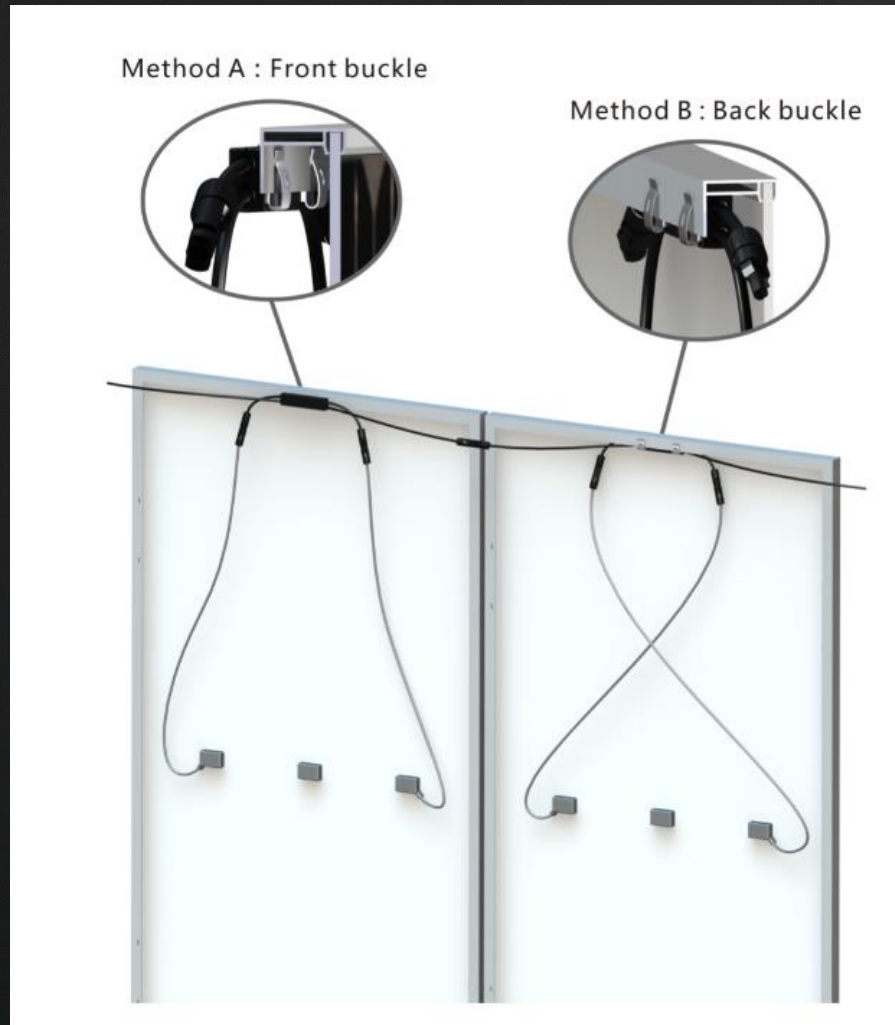

- After connected with PV module, RSD-S-PLC outputs a DC voltage range **0.6 – 1v**.
- Always connected with PV modules **before** connecting homerun to inverter's MPPT.

Step 1: RSD-S-PLC Mounting

Step 2: Connect With PV Module

Step 3: String Wiring

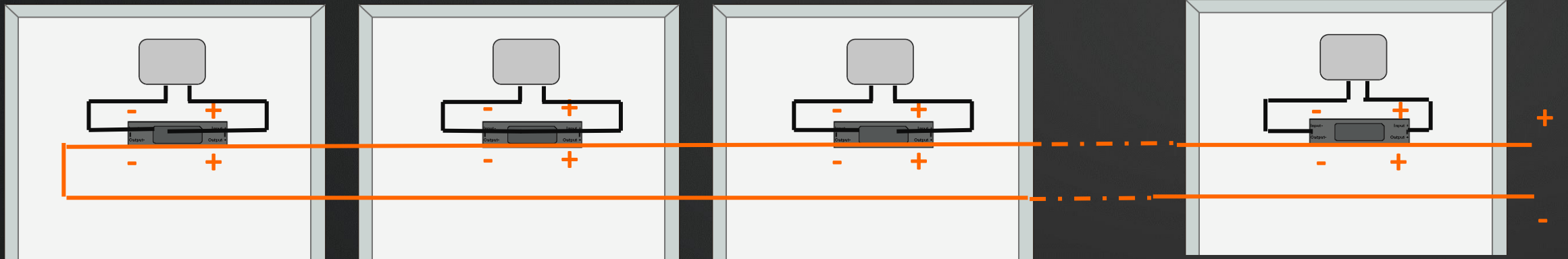

Installation best practice & confirmation:

- Step 1: Connecting RSD-S-PLC with PV module first:

$$V_{rsd} = 0.6 \sim 1v$$

- Step 2: Connecting RSD-S-PLCs together into string, measure each string's open-air DC voltages before connect to MPPT:

$$V_{string} = (0.6 \sim 1v) \times \#RSD-S-PLCs$$

- Step 3: Comparing each string's DC voltages, all should be identical (V_{avg}) as balanced strings on the same MPPT :

Checking connections & devices if strings' DC voltages are varied on the same MPPT.

Step 1: RSD-S-PLC Mounting

Step 2: Connect With PV Module

Step 3: String Wiring

Step 4: Connect to String Inverter

Installation recommendation:

- Mounting RSD-S-PLC devices to PV modules **on the ground**, then move the whole package up to the roof.
- Always connecting homerun to inverter as the **LAST** step after finishing all installs & tests.
- Always disconnecting homerun from inverter as the **FIRST** step before operating any electrical test on modules.

Installation troubleshooting & commissioning :

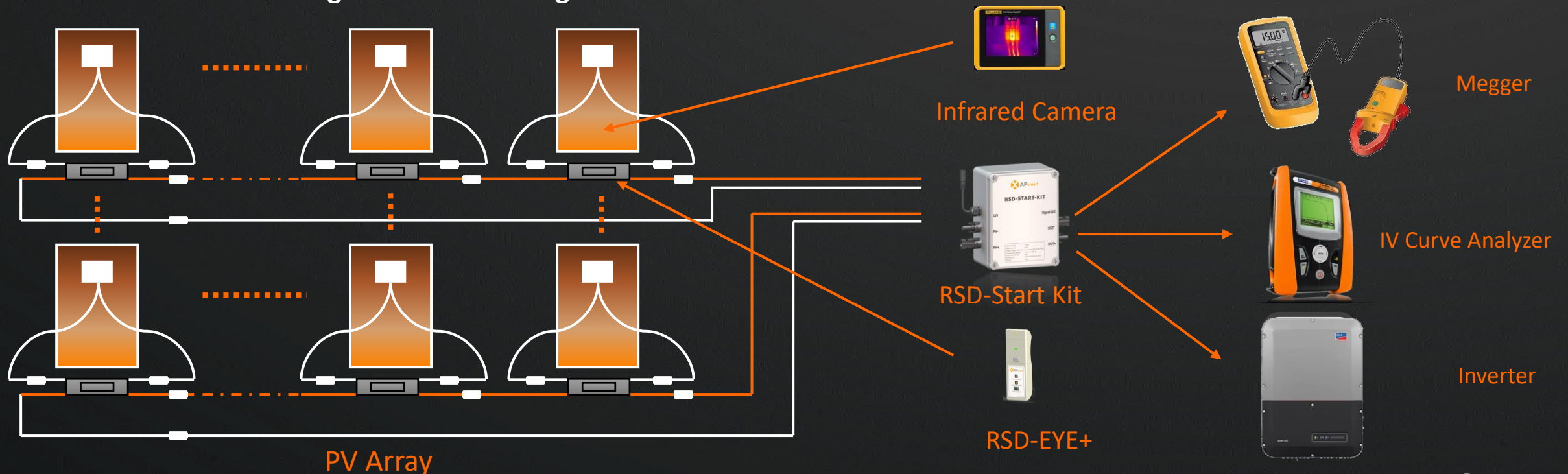

System Initial State

After the system is set up, the initial state of the RSD-S-PLC is **OFF**, the PV strings must less than **30V** voltage output. Confirming the communication protocol profile inside SMA cloud portal is on **“SunSpec”** before turn on inverter.

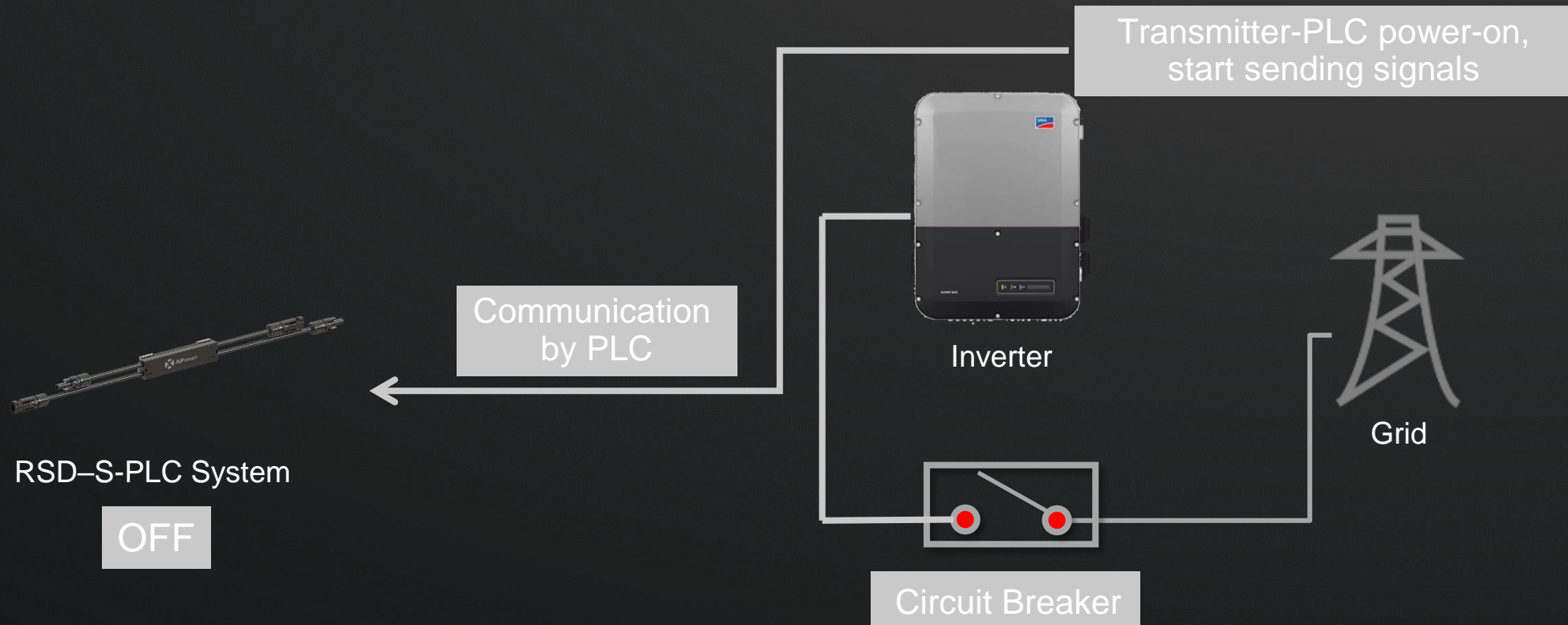

System Startup

After turning on circuit breaker from AC grid, the inverter and its transmitter will be powered on at the same time. The transmitter then sends PLC signal to the RSD-S-PLC units, they will turn on PV modules power outputs within 10s after receiving the signal.

SMA inverter requires string level DC voltages **between minimal of 6 PV modules (above 3.5v), below 30 modules (30v)** based on SunSpec RSD requirement. System will not be able to turn on if string voltages out of this range.

After waiting 5 minutes, check the MPPTs DC voltage on the inverter screen, ensuring that all RSD-S-PLCs have successfully started up.

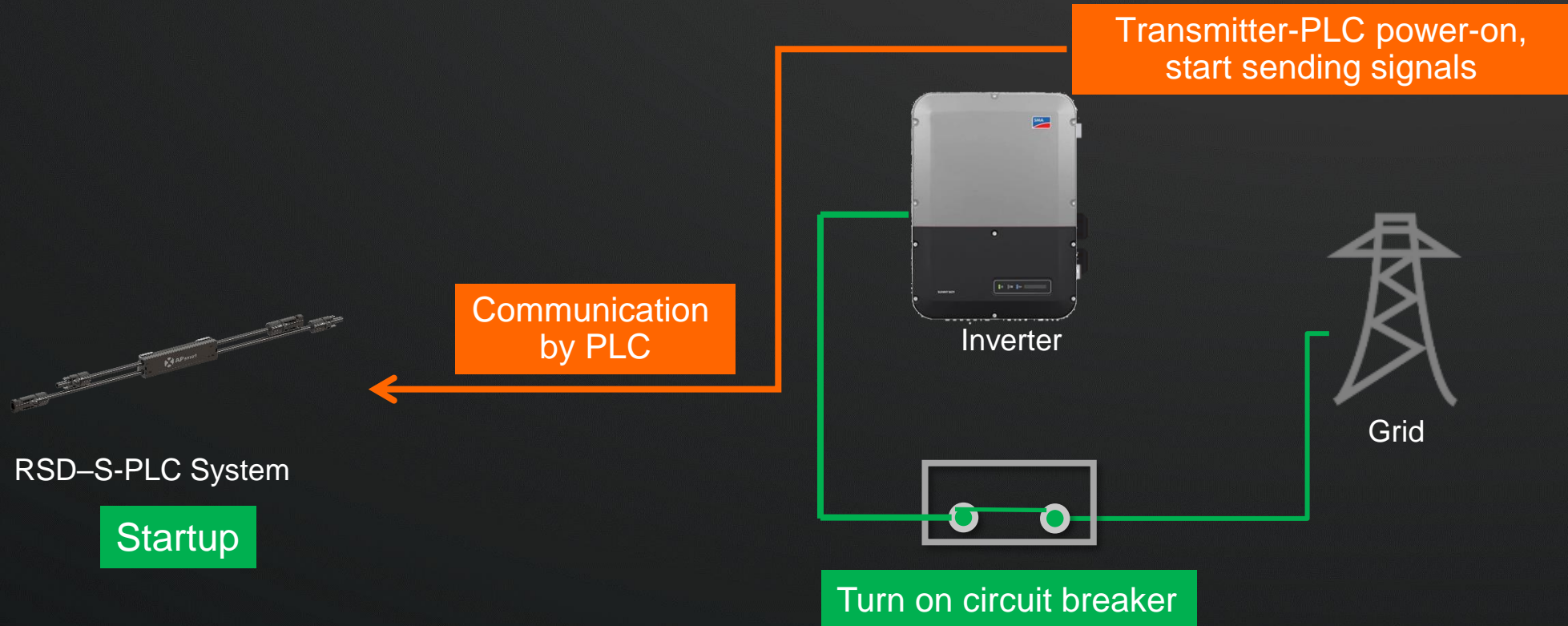

System Shutdown

When the circuit breaker on the inverter AC side is on the off position, the inverter and transmitter will be jointly powered off. The transmitter then stops sending the signal to the RSD-S-PLC units, then it will shut down the PV module power output within 10s.

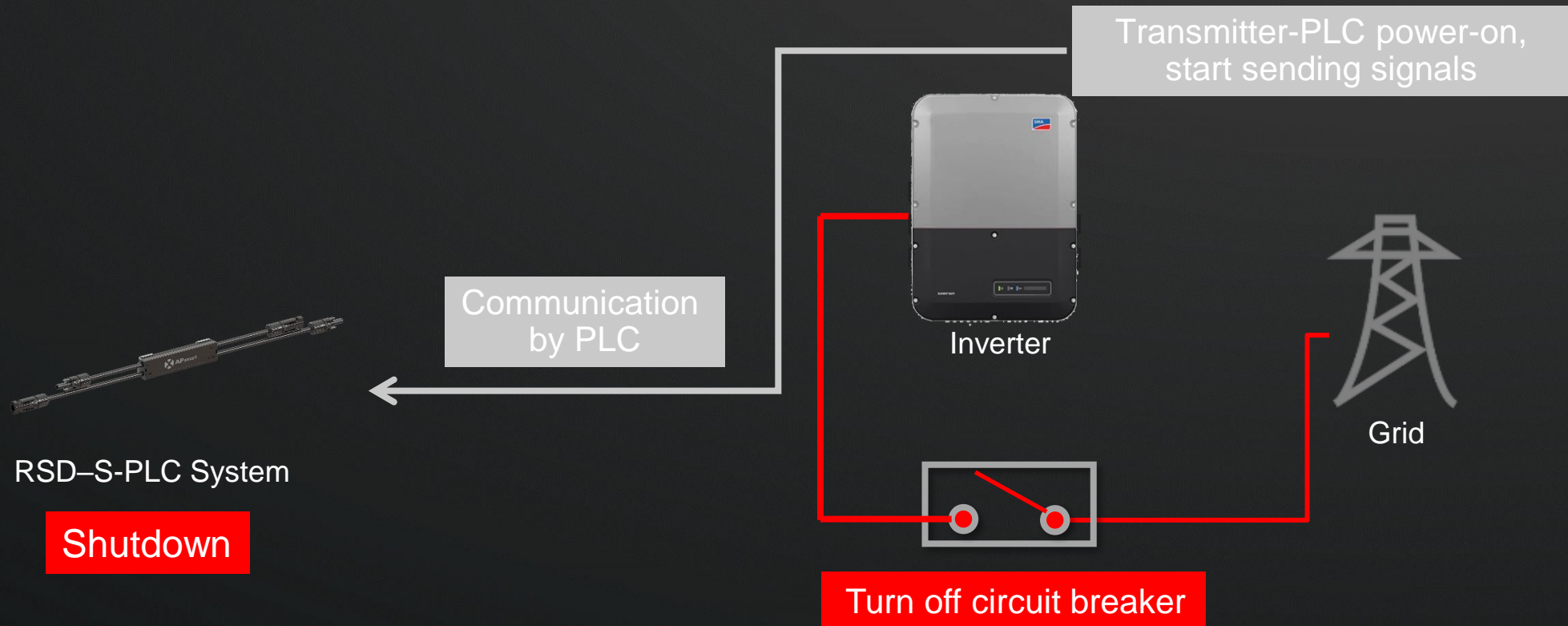

APsmart MLRSD Monitoring & Troubleshooting

String Inverter Real-Time Monitoring Portal – DC Voltages on MPPTs

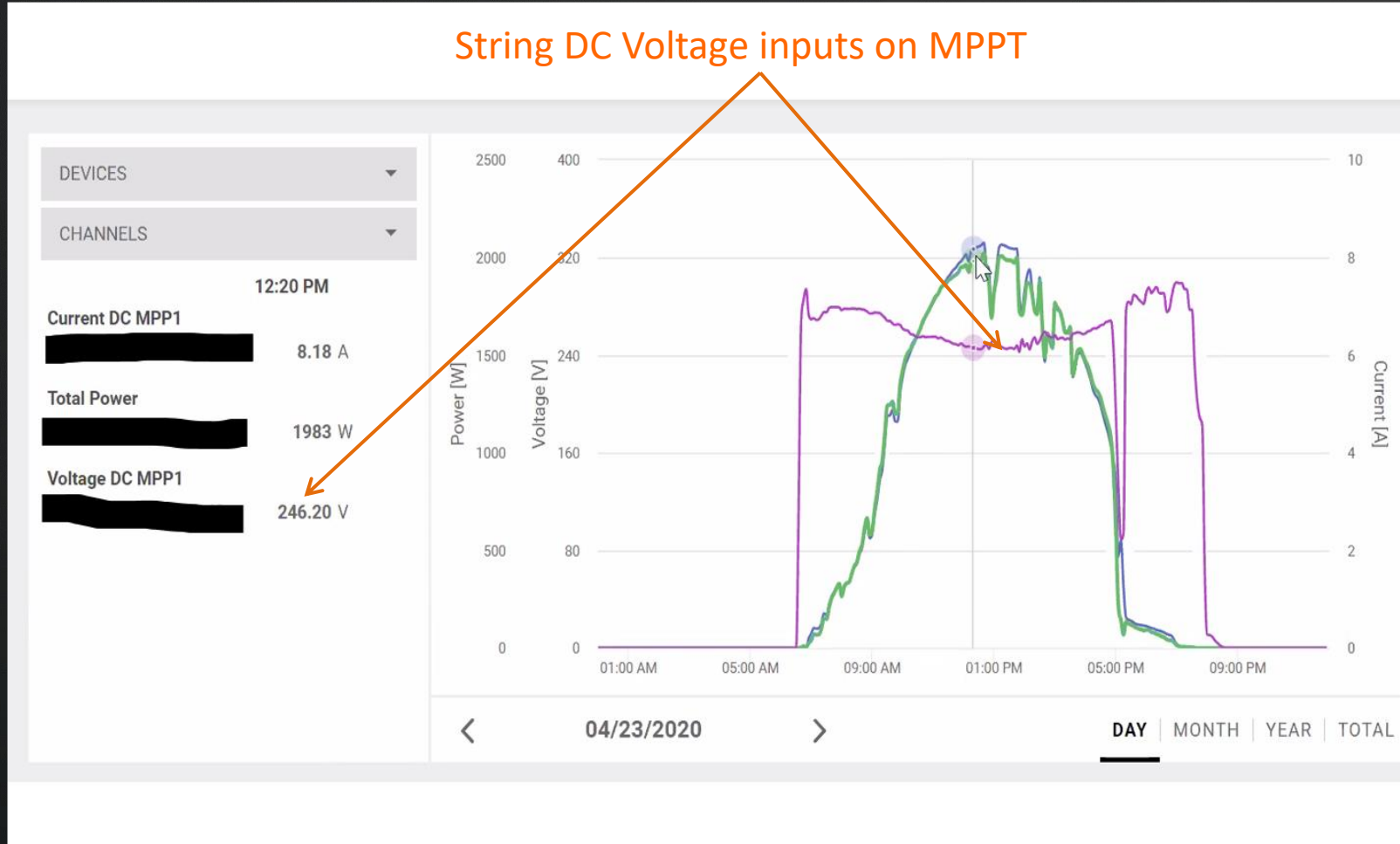

RSD-S-PLC Performance in the Field Summary

- Since APsmart RSD devices exactly followed NEC 2017 690.12 Rapid Shutdown standard, it only applied single PV module voltages (< 80v) on terminals, also device is fully potted by Silicone within UL rated enclosure, fundamentally **reduced** the risk of **MLPE firing on the rooftop**. Based on field data so far, has been proved APsmart RSD solution **will NOT cause fire on the rooftop, with 0% & 0 case over 500K installed worldwide**.
- The highest failure rate component is **MOSFETs**, caused them either opened or shorted with thermal runaway, eventually bubbled on enclosure and bypass the module. **It is detectable by monitoring string inverter's performance portal each MPPT voltages level**.
- The overall failure rate in the field so far is less than **0.02%** for above 500K devices are running WW (based on the RMA data from Q2 2021).

APsmart Products Failure Mode: RSD-S-PLC's MOSFETs

MOSFETs Failure Mode:

- RSD-S-PLC is opened to **bypass** the module ($V_{rsd_out}=0v$), cause PV system has **string operating DC voltage dropped constantly after system turns on.**

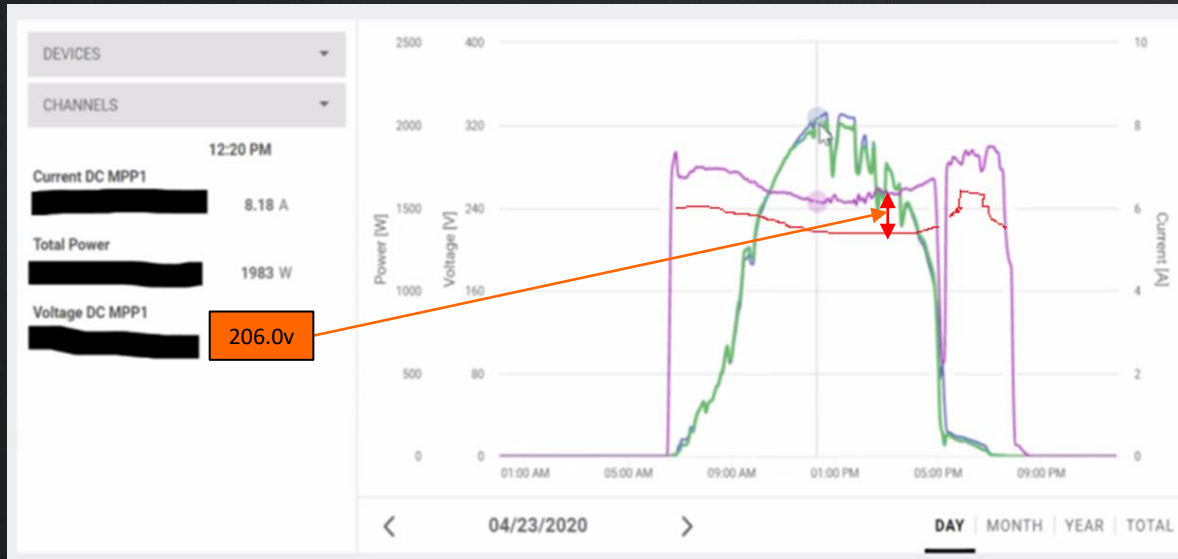

Performance: MPPT DC Voltages drop



Visual Inspection: Enclosure bubbling

- RSD-S-PLC is shorted to **open** the module ($V_{rsd_out}>1v$), cause device lost its Rapid Shutdown function, **string open-air DC voltage will be greater than 1v X # RSD-S-PLCs, then damaged by thermal & bypass.**

APsmart Products Failure Mode: Solder Joint Arcing (Worst Case)

Low voltages arcing < 80v Failure Mode (Failure rate is very low):

- RSD-S-PLC is arcing on positive input terminal due to soldering joint variations, caused **thermal damaging on PCBA and melting the enclosure, Silicone potting will be smoking out without flaming**.



Visual Impact: Silicone smoking out, discolored backsheet, melted enclosure

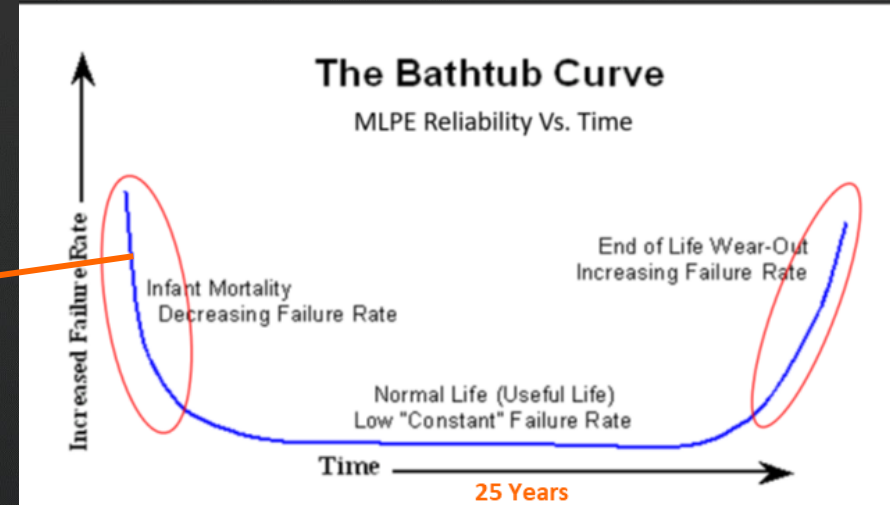

MLPE Products Reliability & Lifetime

High voltages arcing > 80v Failure Mode (Failure rate is extremely low):

- RSD-S-PLC is arcing on positive output terminal, under full homerun string voltages, caused homerun **opening circuit ($V_{string} = 0v$), triggering AFCI alert on string inverter then shut down the system**.

RSD Receivers Troubleshooting Steps:

Step1: Identify failed inverter/MPPT have dropped DC output voltages



Step2: Identify failed strings on MPPT have changed DC open-air voltages



Step3: Locate failed devices inside this string by thermal detectors.



Step4: Switch-off grid, confirm suspect device by DMM & RSD-EYE+

RSD Failures Determined on System Level – Inverter/MPPT’s Operating Voltages Drop

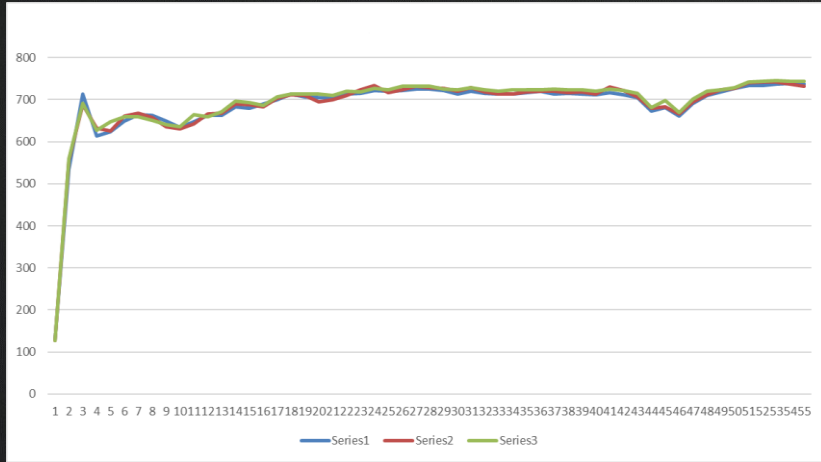

Inverter has no failed devices

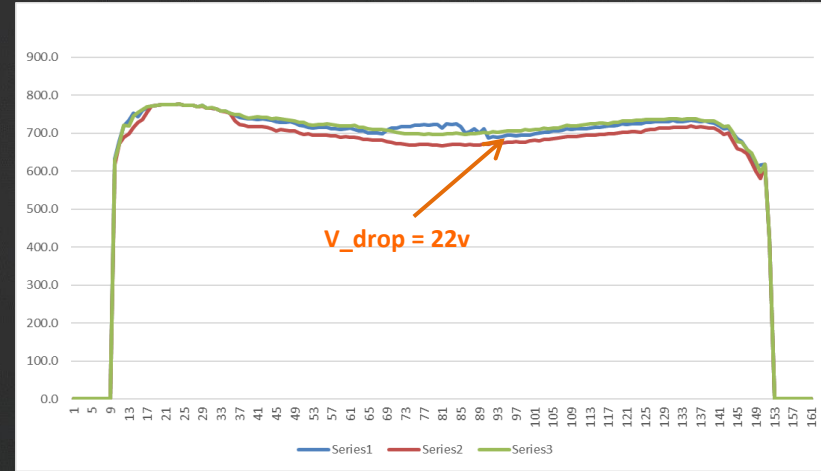

Inverter has one failed devices in MPPT#3

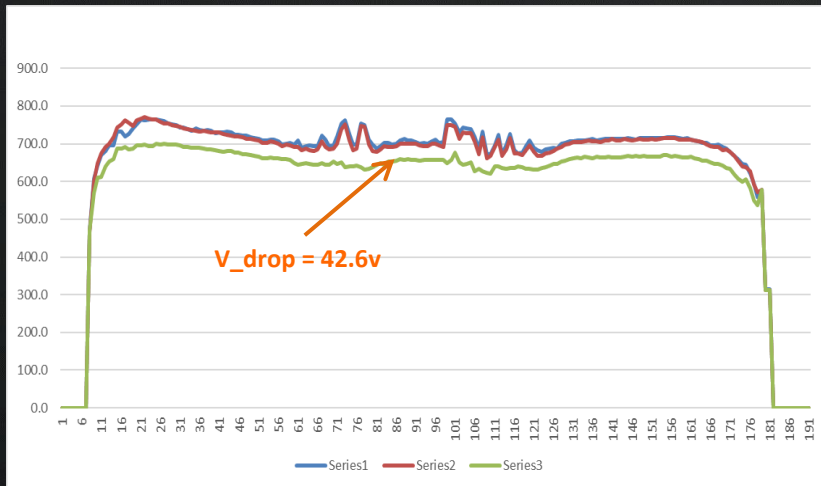

Inverter has 2 failed devices in MPPT#3

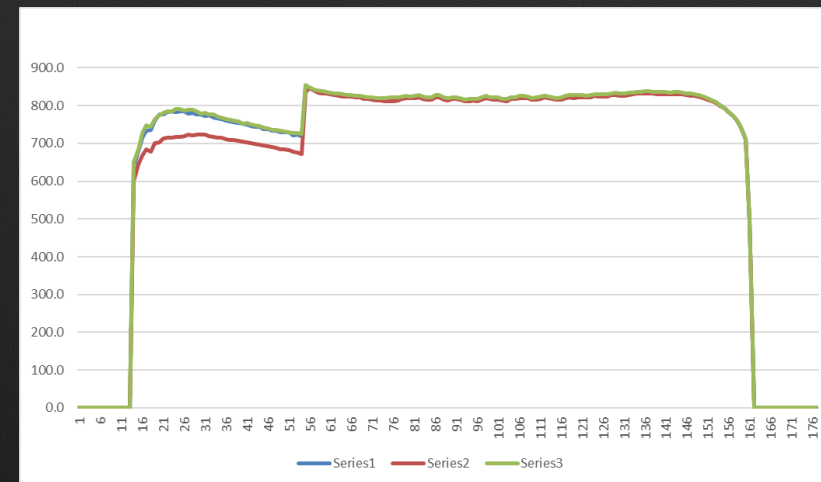

Inverter replaced failed devices and system recovered

RSD Failures Determined on String Level – String Open-Air Voltages Changed

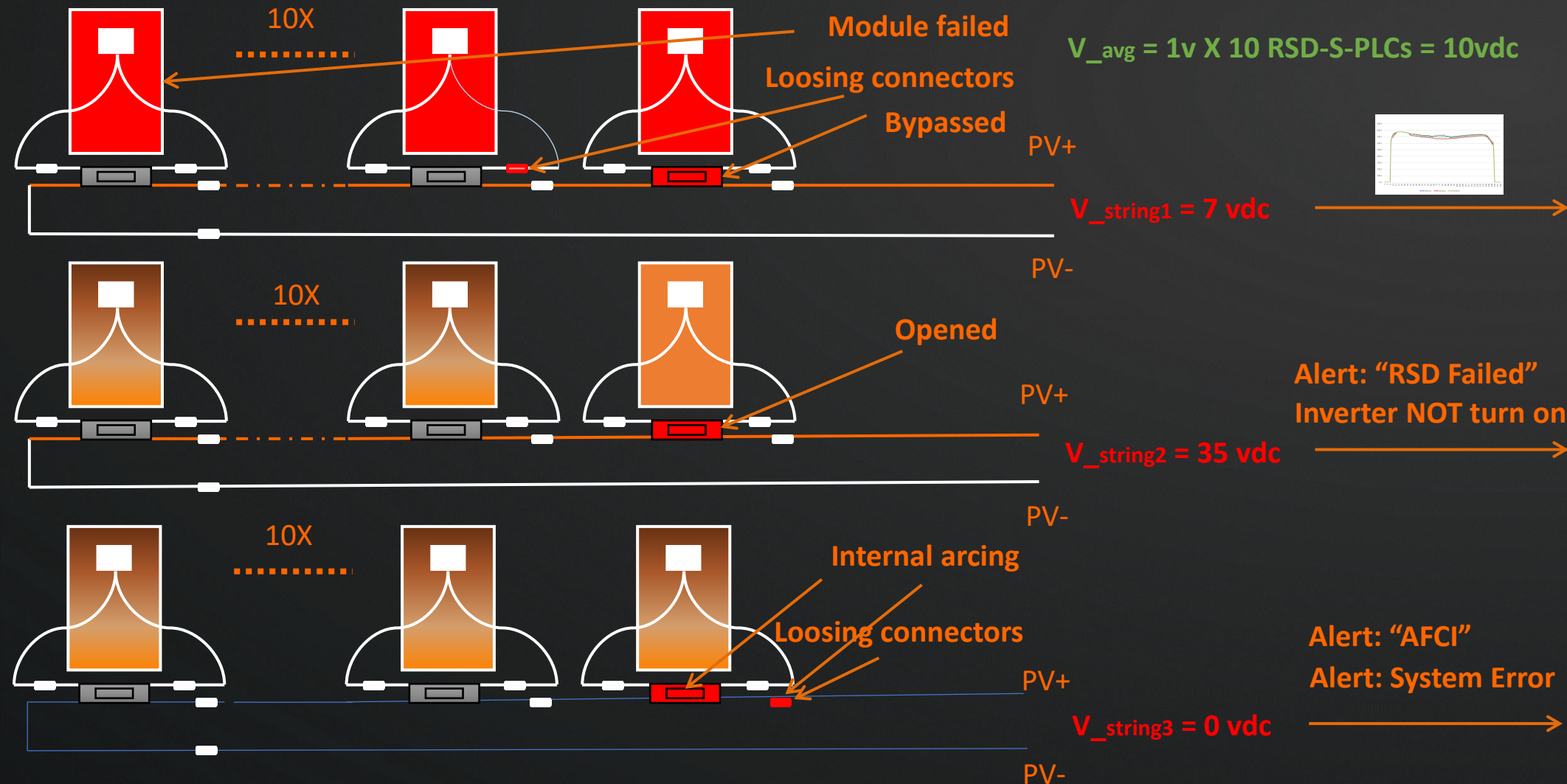

Inverter

RSD Failures Determined on Module Level – Located by vary tools



Infrared Camera

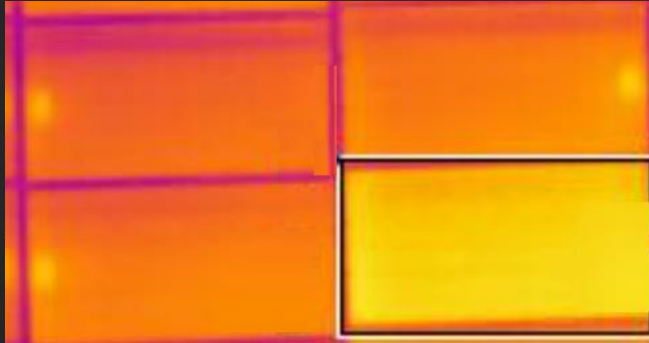

Bypassed: "Light module" when RSD receivers are on
 Opened: "Dark module" when RSD receivers are off



RSD-EYE+ Detector

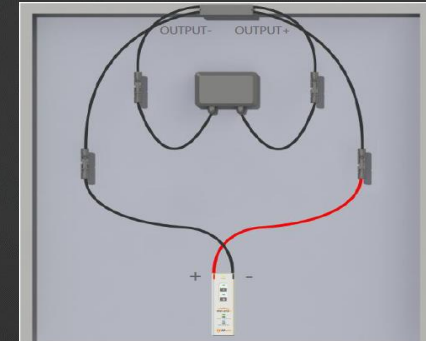

Bypassed: $V_{on} = 0v$
 Opened: $V_{off} > 1v$



Thermometer

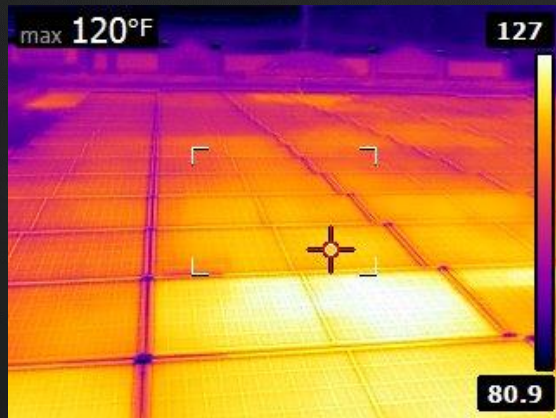

Arcing: "Hot-Spot" when RSD Receiver is on



Clamp DMM

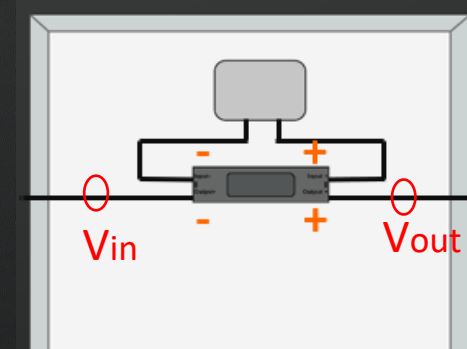

Bypassed: $V_{in} - V_{out} = 0v$
 Opened: $V_{out} - V_{in} > 1v$

RSD Devices Troubleshooting Guidelines & Best Practice:

- RSD system troubleshooting procedure recommendation: it is better to diagnostic the failing points from PV system side to inverter/Grid side, in order to isolate and locate the failed parts easier. After confirming PV array has no issues, then next to check the inverter function. **Always calling APsmart technical support first!**
- APsmart RSD devices had been carefully designed to ignore the “AFCI Unwanted Tripping” issue, so if SMA inverter is alerting on AFCI, it must have the arcing occurred somewhere in the system, engineers need to investigate immediately onsite. **If AFCI caused by RSD internal arcing, by investigating earlier, it will significantly reduce the comprehensive thermal damages on module!**
- Troubleshooting best practices: **De-energize system and inverters first.**
 - Disconnecting homerun from inverter first, then following the troubleshoot steps to find out failed strings;
 - Using combination of RSD Start Kit & thermal detectors (IR camera or thermometer) to locate failed parts;
 - Using RSD-EYE+ or DMM to confirm the failed RSD devices.

Reliability Evaluation Program by PVEL – Accelerated Lifetime Test



Figure 2-1: Test plan process diagram

PVEL ALT Program



3.3 Post Passive Chamber Evaluation- TC400

3.3.1 Visual Inspection

No visual defect or change was observed as a function of passive chamber stress.

3.3.2 Verification of MLRSD Operation

In an ambient environment, the functional test repeatedly tested the ability of the RSD to reduce DC voltage below the threshold value within 30 seconds upon the loss of AC voltage. This is graphically presented in Figure 3-15 and Figure 3-16.

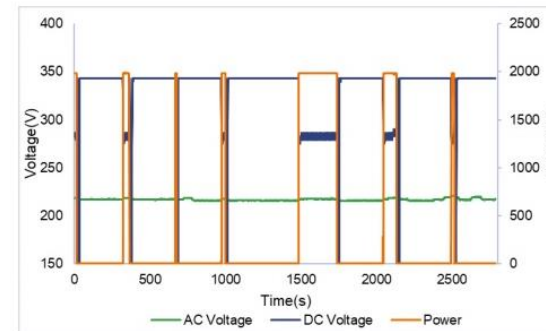

Figure 3-15: Functional Test Evaluation

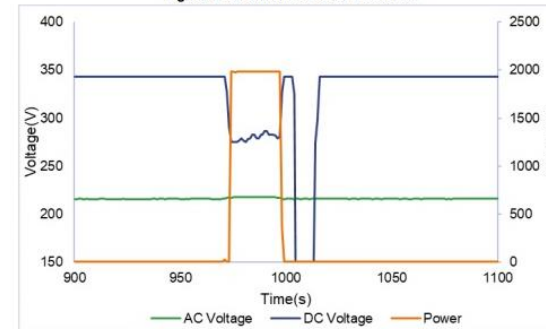

Figure 3-16: Functional Test Evaluation – Detail

Thermal Cycling 400 Cycles Result

APsmart MLRSD Technical Support & RMA Process

Applications Support: <https://apsmartglobal.com/library/>

APsmart

Why APsmart | News | Partners | Resources | **Contact**

Contact APsmart

Get in Touch

Our team here at APsmart are committed to providing the highest quality service to our customers and partners.

[Join our interest list](#)

Company Name *

Contact Name *

First Last

Email *

Phone *

Country *

APsmart Location

600 Ericksen Ave NE, Suite 200
Seattle, WA 98110
United States of America
Phone: 737-218-8486
Email: info@APsmartGlobal.com

[SUPPORT](#)



**LOOKING FOR APSYSTEMS
MICROINVERTERS?**

APsystems.com

Information request online portal: <https://apsmartglobal.com/#contact>

Installers Support:

RSD-S-PLC

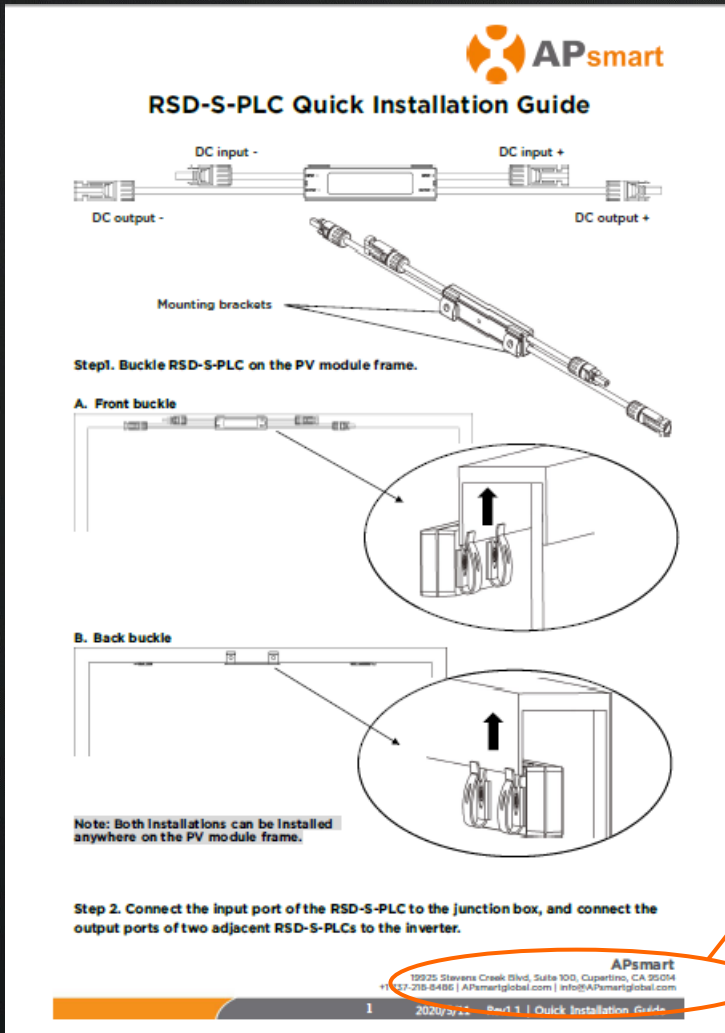

APsmart
RSD-S-PLC Quick Installation Guide

DC input - DC input +
 DC output - DC output +

Mounting brackets

Step 1. Buckle RSD-S-PLC on the PV module frame.

A. Front buckle

B. Back buckle

Note: Both installations can be installed anywhere on the PV module frame.

Step 2. Connect the input port of the RSD-S-PLC to the junction box, and connect the output ports of two adjacent RSD-S-PLCs to the inverter.

APsmart
 12225 Stevens Creek Blvd, Suite 100, Cupertino, CA 95014
 +1-866-374-8538 | APsmartglobal.com | info@APsmartglobal.com

1 2020/3/11 Rev 1.1 | Quick Installation Guide

Technical Support:
 Email: support@apsmartglobal.com
 Web: <https://apsmartglobal.com/support/>
 Support Hotline: 1-866-374-8538



Product Label

RSD-D

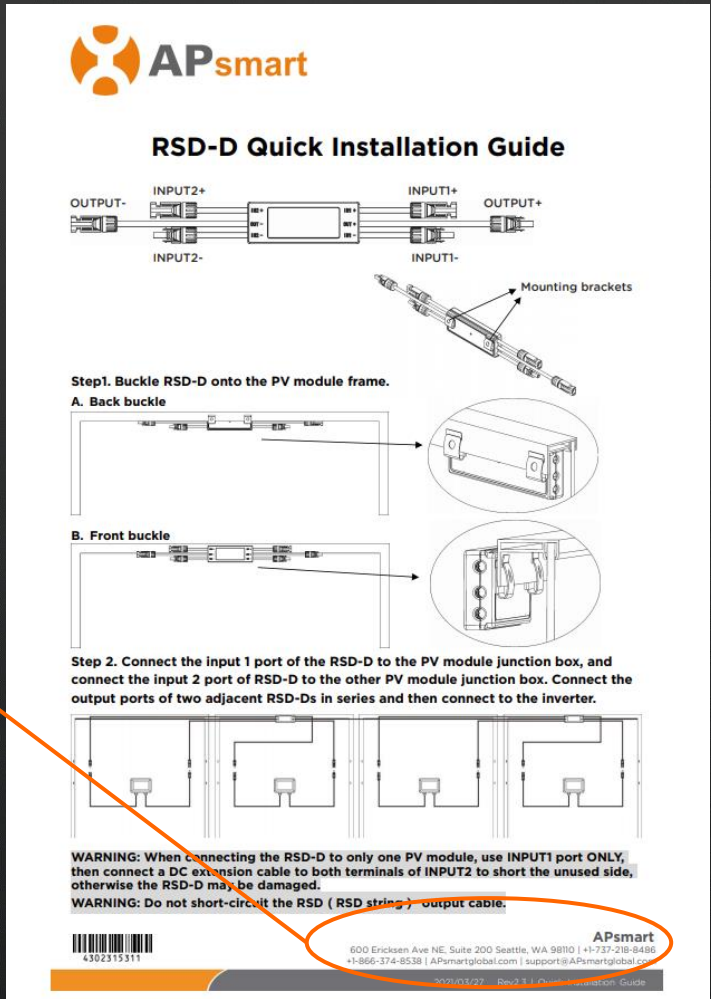

APsmart
RSD-D Quick Installation Guide

OUTPUT- INPUT2+ INPUT1+ OUTPUT+
 INPUT2- INPUT1-

Mounting brackets

Step 1. Buckle RSD-D onto the PV module frame.

A. Back buckle

B. Front buckle

Step 2. Connect the input 1 port of the RSD-D to the PV module junction box, and connect the input 2 port of RSD-D to the other PV module junction box. Connect the output ports of two adjacent RSD-Ds in series and then connect to the inverter.

WARNING: When connecting the RSD-D to only one PV module, use INPUT1 port ONLY, then connect a DC extension cable to both terminals of INPUT2 to short the unused side, otherwise the RSD-D may be damaged.
WARNING: Do not short-circuit the RSD (RSD string) output cable.

APsmart
 600 Erickson Ave NE, Suite 200 Seattle, WA 98110 | +1-737-218-8486
 +1-866-374-8538 | APsmartglobal.com | support@APsmartglobal.com

4302313311 2020/3/11 Rev 1.1 | Quick Installation Guide

O&M Support: Technical Support Request Online Portal & RMA Request Form

<https://apsmartglobal.com/support/>

<https://apsmartglobal.com/library/>

Technical Support Process Cooperating with SMA Service

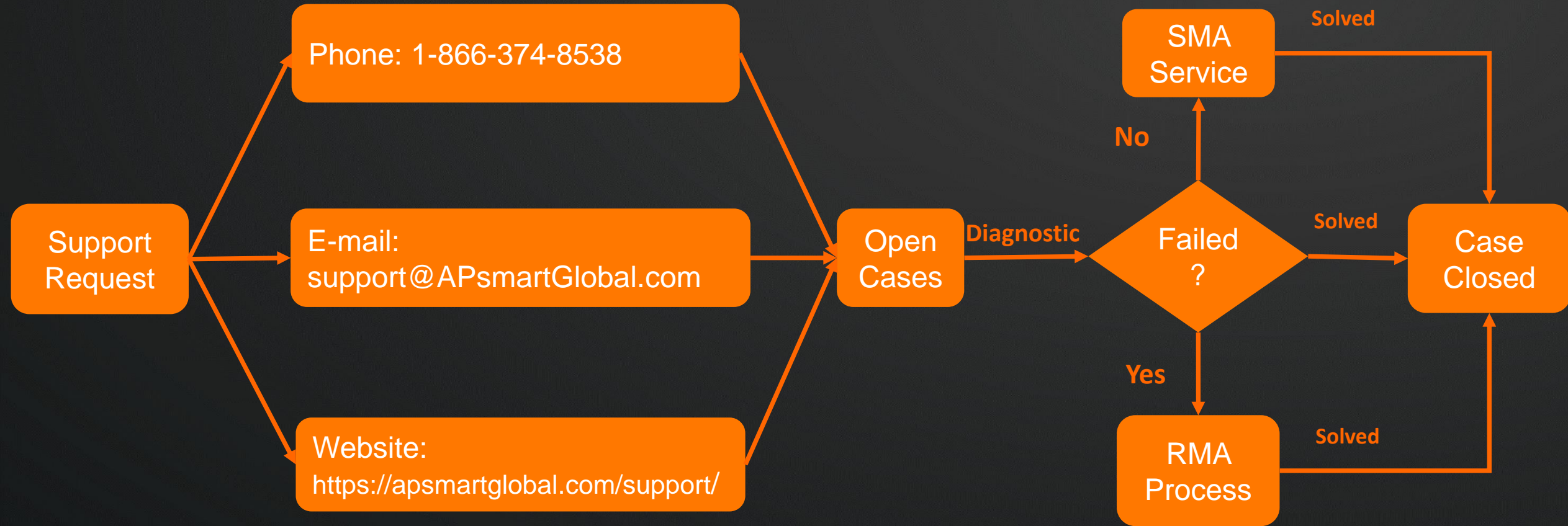

APsmart RMA Process: For All End Users

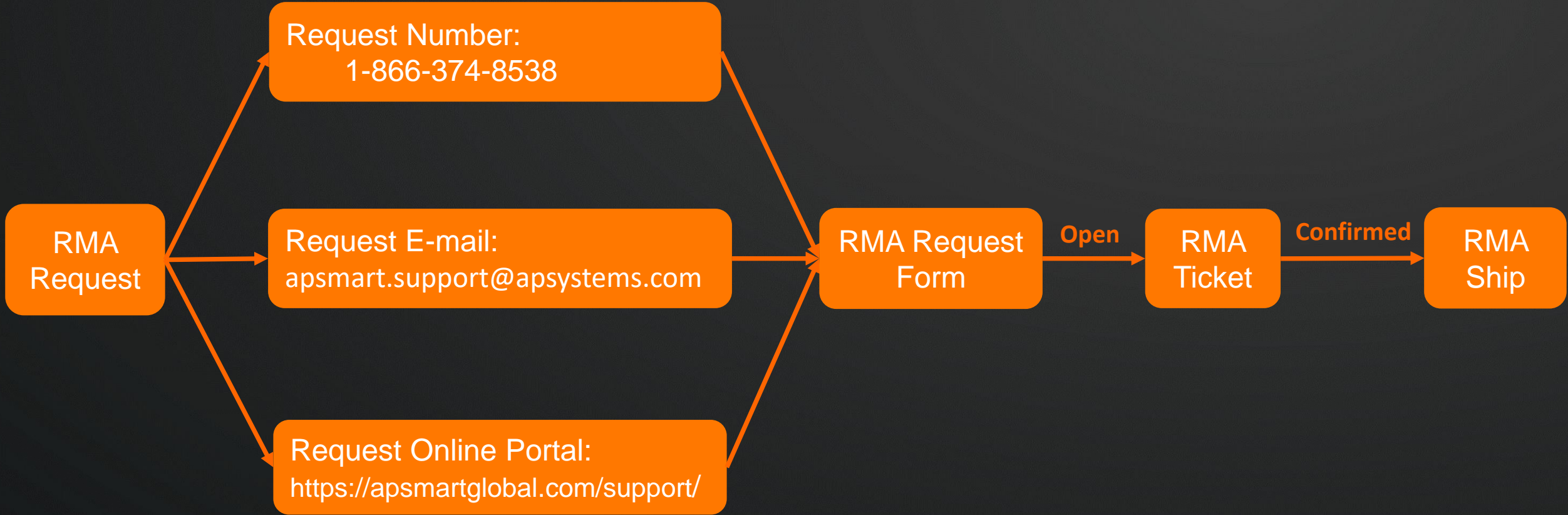

Manufacture Warranty



APsystems Limited Warranty for Rapid Shutdown Devices & Transmitter

Altenergy Power System, Inc. (“APsystems”) provides Rapid Shutdown Devices, including RSD-S-PLC and RSD-D, Transmitter-PLC, Transmitter-PLC Outdoor Kit, and RSD-EYE+. This Limited warranty (“Limited Warranty”) covers defects in workmanship and materials of the Equipment for the specified duration (“Warranty Period”) described below:

- RSD-S-PLC and RSD-D: twenty-five (25) years beginning on the earlier of (“Warranty Start Date”): (i) 4 months from the date the Equipment is shipped from APsystems; and (ii) the installation of the Equipment (“Warranty Start Date”). For PV module-embedded Equipment, the Warranty Period shall not exceed the maximum of (1) the PV module product warranty period and (2) the PV module power warranty period provided by the PV module manufacturer.
- Transmitter-PLC: ten (10) years beginning on the Warranty Start Date. For inverter-embedded Equipment, the Warranty Period shall not exceed the inverter product warranty period provided by the inverter manufacturer.
- Transmitter-PLC Outdoor Kit: three (3) years beginning on the Warranty Start Date, when used with the APsystems Rapid Shutdown Devices.
- RSD-EYE+: one (1) year beginning on the Warranty Start Date, when used with the APsystems Rapid Shutdown Devices.

<https://apsmartglobal.com/library/>

Thank you!

For more information, visit

APsmartglobal.com

You can also email us at: info@APsmartGlobal.com

call us at: **7372188486**