

RSD-S-PLC Quick Installation Guide

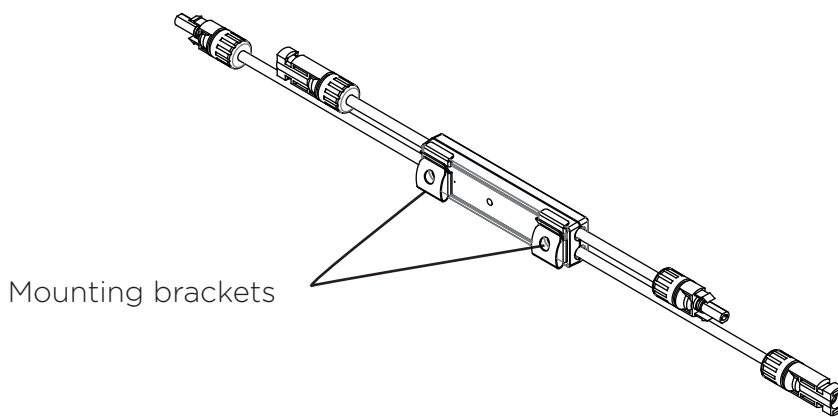

Step 1. Buckle RSD-S-PLC onto the PV module frame.

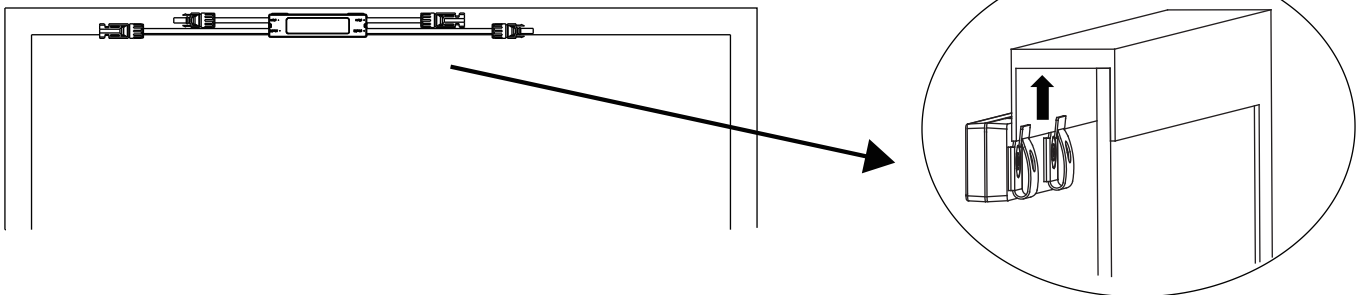

NOTE: Do not place the RSD-S-PLC (including DC connectors) where exposed to the sun, rain or snow, even gap between modules. Allow a minimum of 3/4" (1.5cm.) between the roof and the bottom of the RSD-S-PLC to allow proper air flow.

Step 2. Connect the input connectors of the RSD-S-PLC to the junction box, the device output DC voltage is within the range of 0.6 to 1v.

NOTE: Do not short-circuit the RSD-S-PLC output connectors, otherwise it will be damaged.



NOTE: When installing RSD-S-PLC cable, the bending radius of the cable near the casing must be greater than 50 mm.

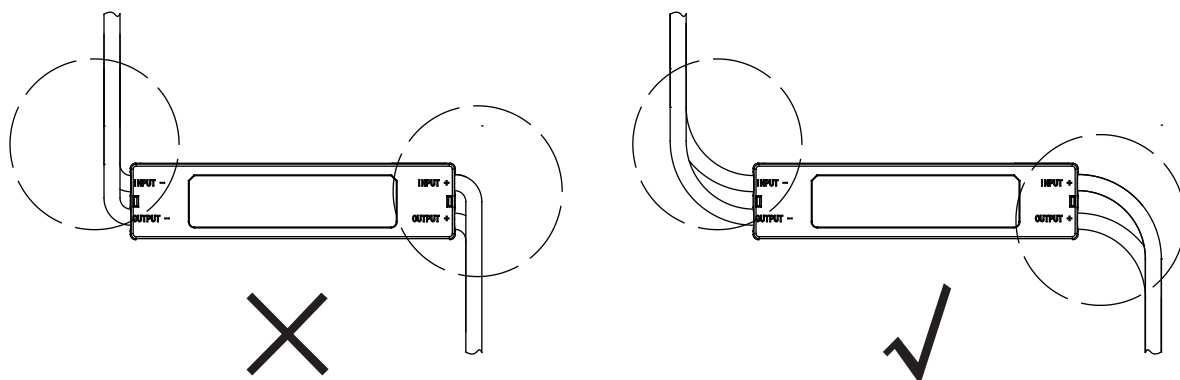

Bending Radius of the cable >50mm

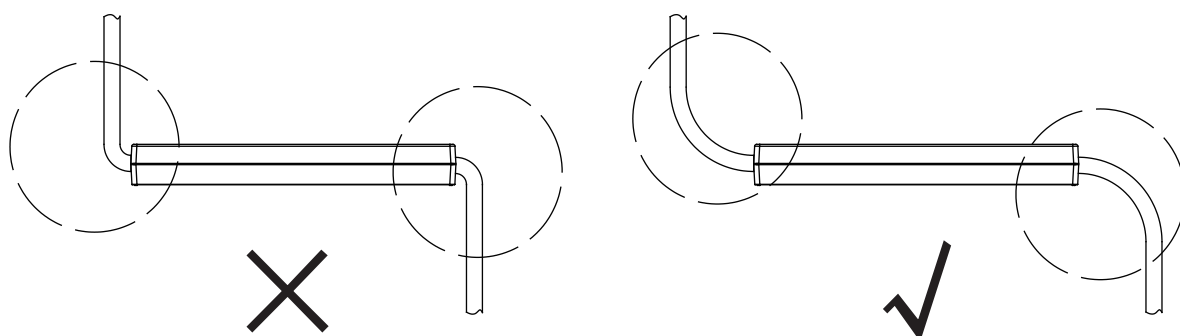

Step 3. Connect the output connectors of the RSD-S-PLC in series to the string, the string open-air DC voltage is within the range of $(0.6 \sim 1v) \times \#RSD-S-PLCs$. (This range may vary due to different on-site environment.)

NOTE: Do not connect homerun to inverter before finishing all strings connections and tests.

NOTE: Please use the same type of DC connector as the RSD in the system. The RSD damage caused by using different type of DC connector will not be covered by the warranty.