

# RSD-S-PLC Quick Installation Guide

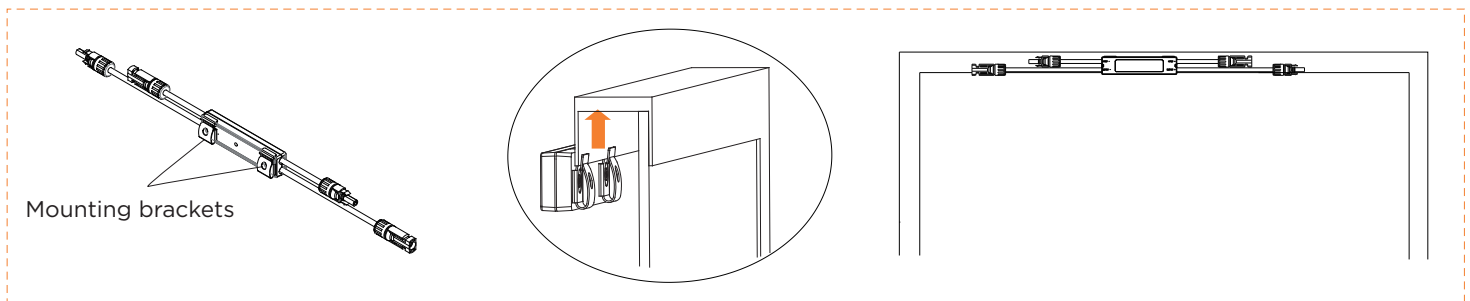

## Step 1 Buckle RSD-S-PLC onto the PV module frame.



**NOTE:** Do not place the RSD-S-PLC (including DC connectors) where exposed to the sun, rain or snow, even gap between modules. Allow a minimum of 3/4"(1.5cm.) between the roof and the bottom of the RSD-S-PLC to allow proper air flow.

## Step 2 Connect the input connectors of the RSD-S-PLC to the junction box, the device output DC voltage is within the range of 0.6 to 1v.

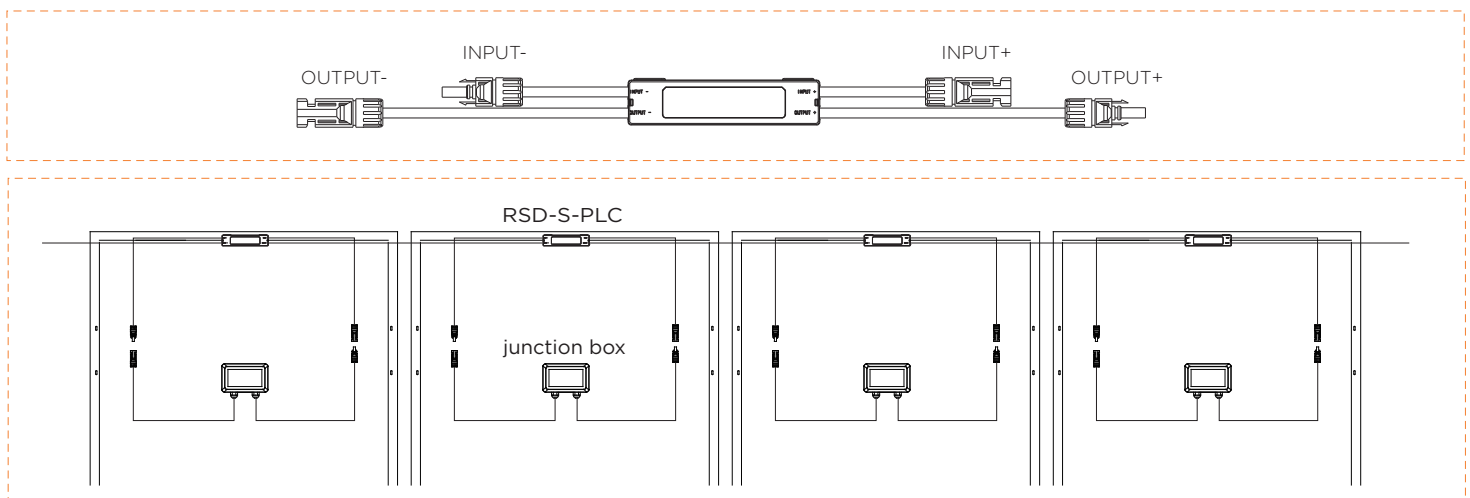

**NOTE:** Do not short-circuit the RSD-S-PLC output connectors, otherwise it will be damaged.

**NOTE:** When installing RSD-S-PLC cable, the bending radius of the cable near the casing must be greater than 50 mm.

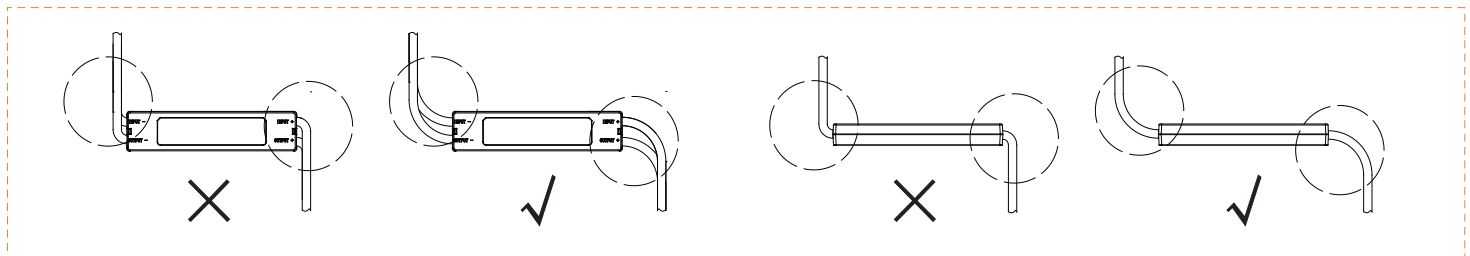

## Step 3 Connect the output connectors of the RSD-S-PLC in series to the string, the string open-air DC voltage is within the range of (0.6 ~ 1v) X #RSD-S-PLCs. (This range may vary due to different on-site environment.)

**NOTE:** Do not connect homerun to inverter before finishing all strings connections and tests.

**NOTE:** Please use the same type of DC connector as the RSD-S-PLC in the system. The RSD-S-PLC damage caused by using different type of DC connector will not be covered by the warranty.



Please scan the code to obtain the installation video

APsmart YouTube



Please scan the QR code to access the APsmart website

APSMART



4301615331

2024/06/13 Rev3.0 | Quick Installation Guide

Product information is subject to change without notice. (Please download manuals at APsmartglobal.com).