



Installation/User Manual

APsmart Rapid Shutdown Device & Transmitter

(For APAC)

Rev1.4 2025/02/12

RSD-S-PLC
TRANSMITTER-PLC
TRANSMITTER-PLC OUTDOOR KIT

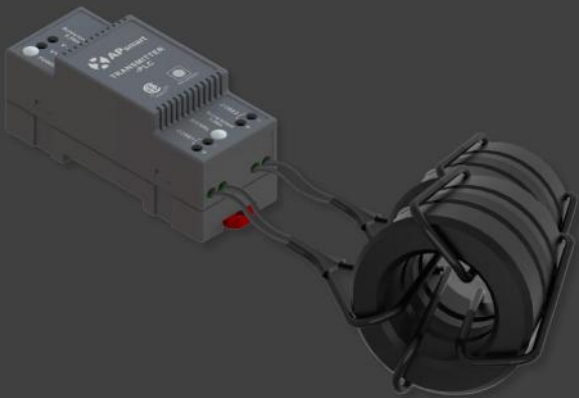

TABLE OF CONTENTS

IMPORTANT SAFETY INSTRUCTIONS-----	1
RSD PRODUCTS-----	2
TRANSMITTER PRODUCTS-----	3
SYSTEM WIRING DIAGRAM-----	4
RSD-S-PLC INSTALLATION-----	6
TRANSMITTER-PLC INSTALLATION -----	10
TECHNICAL DATA—RSD-S-PLC-----	17
TECHNICAL DATA—TRANSMITTER-PLC-----	18
TECHNICAL DATA—TRANSMITTER-PLC-OUTDOOR KIT-----	19
ORDERING INFORMATION -----	20

IMPORTANT SAFETY INSTRUCTIONS

This manual contains important instructions to be followed during installation and maintenance of the APsmart RSD-S-PLC and Transmitter. To reduce the risk of electrical shock and ensure the safe installation and operation of the APsmart RSD-S-PLC and Transmitter, the following symbols appear throughout this document to indicate dangerous conditions and important safety instructions.



Safety Instructions

- Do NOT disconnect the PV module from the RSD-S-PLC without first disconnecting the AC power.
- Only qualified professionals should install and/or replace the APsmart RSD-S-PLC.
- Perform all electrical installations in accordance with local codes.
- Before installing or using the RSD-S-PLC, please read all instructions and cautionary markings in the technical documents.
- Be aware that the body of the operating RSD-S-PLC is a heat sink and can reach high temperature. To reduce risk of burns, do not touch the body of the RSD-S-PLC.
- Do NOT attempt to repair the RSD-S-PLC. If it fails, contact APsmart Customer Support to obtain an RMA number and start the replacement process. Damaging or opening the RSD-S-PLC will void the warranty.

The power supply of the Transmitter-PLC and the inverter MUST be on the same AC branch circuit as the inverter to meet rapid shutdown requirements.

Qualified personnel:

Person adequately advised or supervised by an electrically skilled person to enable him or her to perceive risks and to avoid hazards which electricity can create. For the purpose of the safety information of this manual, a "qualified person" is someone who is familiar with requirements for safety, electrical systems and EMC and is authorized to energize, ground, and tag equipment, systems, and circuits in accordance with established safety procedures. The inverter and balance of system may only be commissioned and operated by qualified personnel.

RSD PRODUCTS

RSD-S-PLC



- Meets NEC 2017, 2020&2023 (690.12) requirements
- Executes rapid shutdown of system when Transmitter-PLC signal is absent
- Meets SunSpec requirements

The RSD-S-PLC meets SunSpec requirements, maintaining normal function by continually receiving a heartbeat signal from the APsmart Transmitter. The RSD-S-PLC executes rapid system shutdown when the Transmitter signal is absent. Users can manually execute rapid shutdown using the Transmitter breaker switch.*⁽¹⁾⁽²⁾

*⁽¹⁾ RSD-S-PLC does not have automatic shutdown function for arc detection. When the system is abnormal, the transmitter signal is cut off by pulling the gate, which triggers shutdown.

*⁽²⁾ RSD-S-PLC is designed to reduce the risk of fire suppression but does not solve the risk of a arc fire.

TRANSMITTER PRODUCTS

Transmitter-PLC

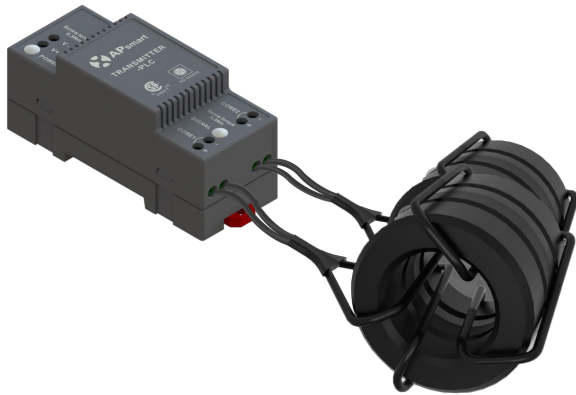

- Meets NEC 2017, 2020&2023 (690.12) requirements
- Switching off Transmitter-PLC results in rapid shutdown of the output of PV modules
- Meets SunSpec requirements
- Equipped with single/dual core
- Optional 85-264VAC power supply
- Optional 180-550VAC power supply

Transmitter-PLC-Outdoor Kit

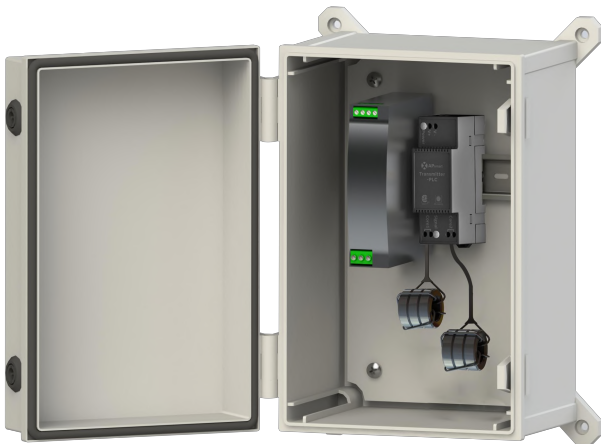

- Meets NEC 2017, 2020&2023 (690.12) requirements
- Switching off Transmitter-PLC results in rapid shutdown of the output of PV modules
- Meets SunSpec requirements
- Equipped with single/dual core
- Optional 85-264VAC power supply
- Optional 180-550VAC power supply

SYSTEM WIRING DIAGRAM

The APsmart Rapid Shutdown System Transmitter-PLC is part of a rapid shutdown solution when paired with APsmart RSD-S-PLC, a PV module rapid shutdown unit. While powered on, the Transmitter-PLC sends a signal to the RSD-S-PLC units to keep the PV modules connected and supplying energy.

RSD-S-PLC units automatically enter rapid shutdown mode when the Transmitter-PLC is switched off and resume energy production when power is restored to the Transmitter-PLC. This solution complies with NEC 690.12 specifications for 2017, 2020&2023 and supports the SunSpec signaling for rapid shutdown.

The Transmitter-PLC includes one or two cores and an optional power supply: 85-264VAC for residential, 180-550VAC for commercial.

Transmitter-PLC Outdoor Kit includes a Transmitter-PLC with one or two cores, outdoor enclosure, 85-264VAC or 180V-550VAC power supply. It could be used in residential or commercial projects.

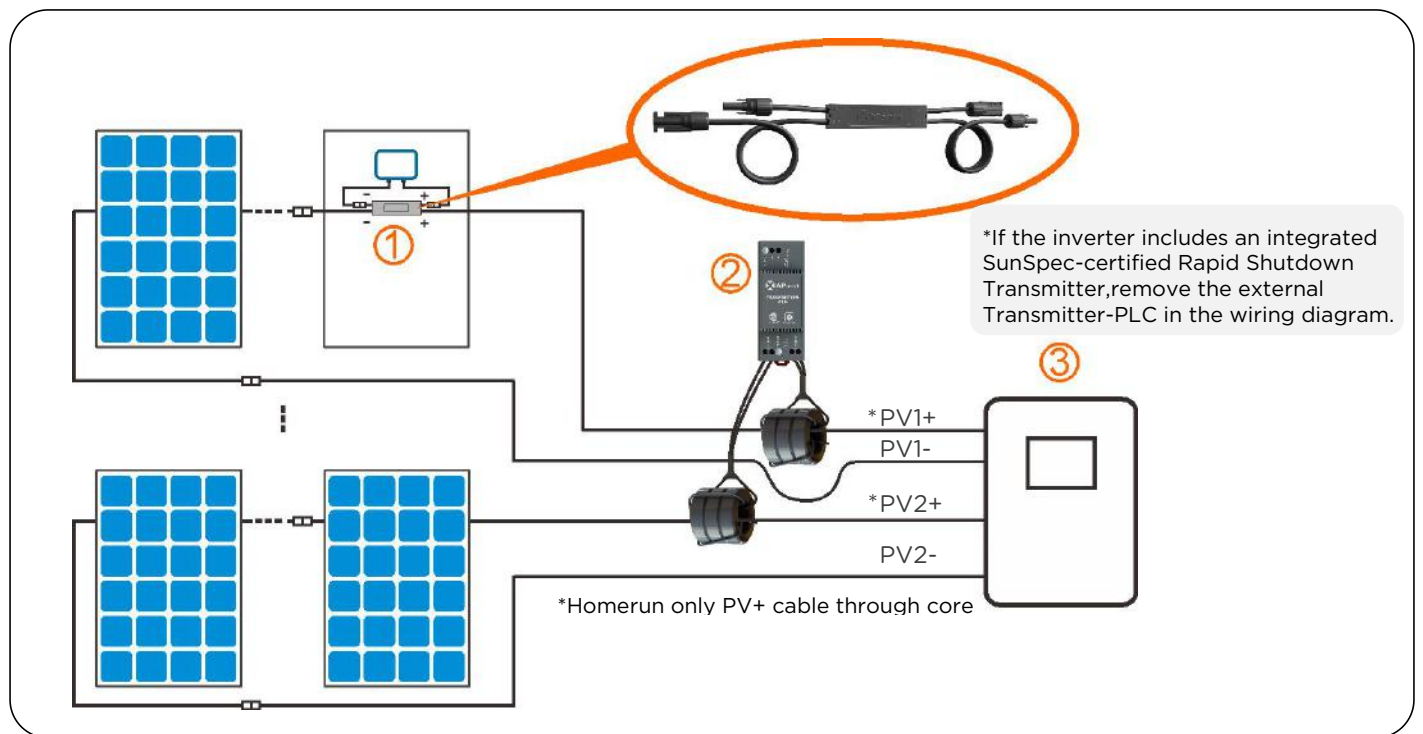

- ① RSD-S-PLC
- ② Transmitter-PLC
- ③ Inverter

SYSTEM WIRING DIAGRAM

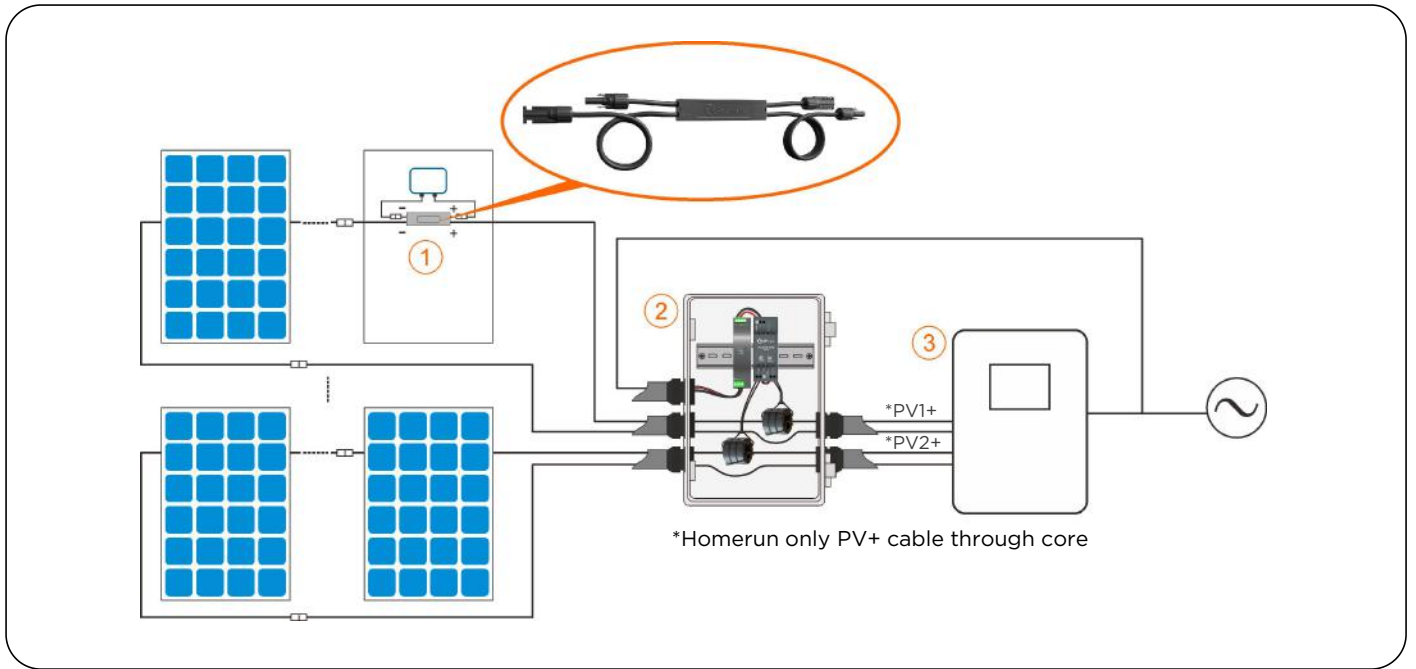

- ① RSD-S-PLC
- ② Transmitter-PLC-Outdoor Kit
- ③ Inverter

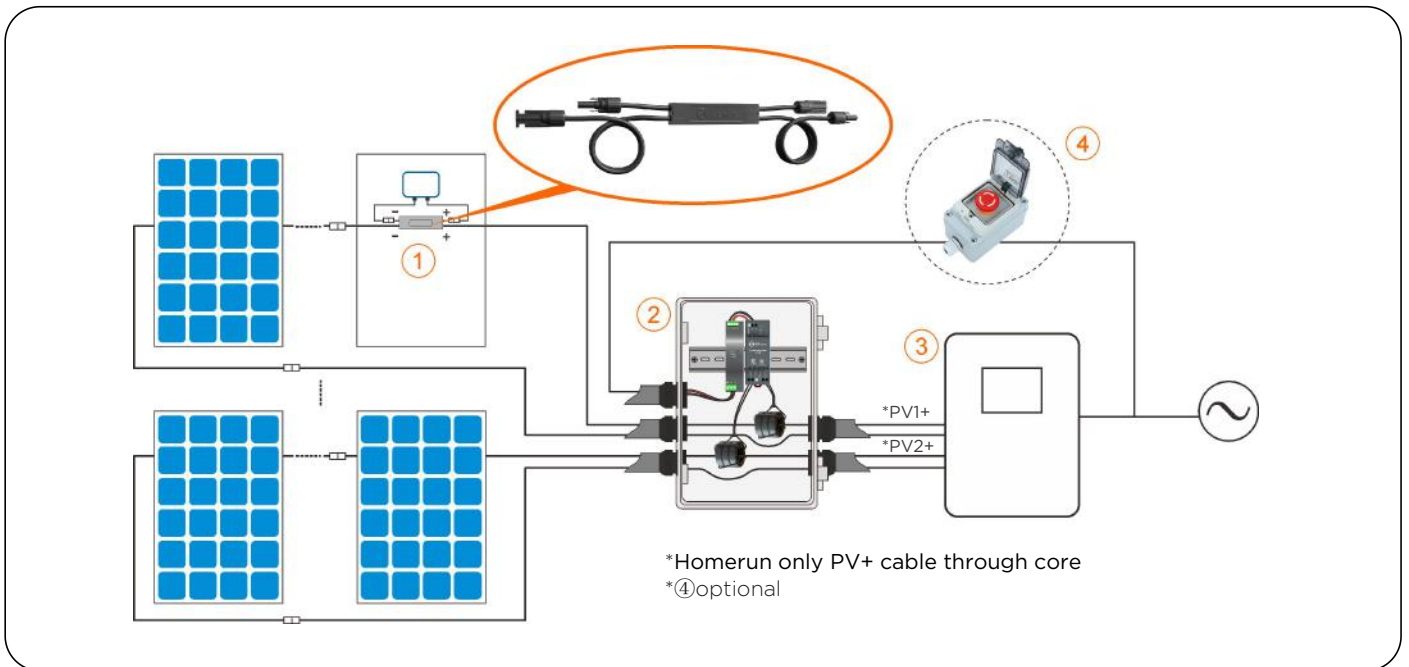

- ① RSD-S-PLC
- ② Transmitter-PLC-Outdoor Kit
- ③ Inverter
- ④ Emergency stop button box (optional) : Press the emergency stop button, the transmitter AC power supply is disconnected, the RSD closes the output, and the system rapid shutdown.

RSD-S-PLC INSTALLATION

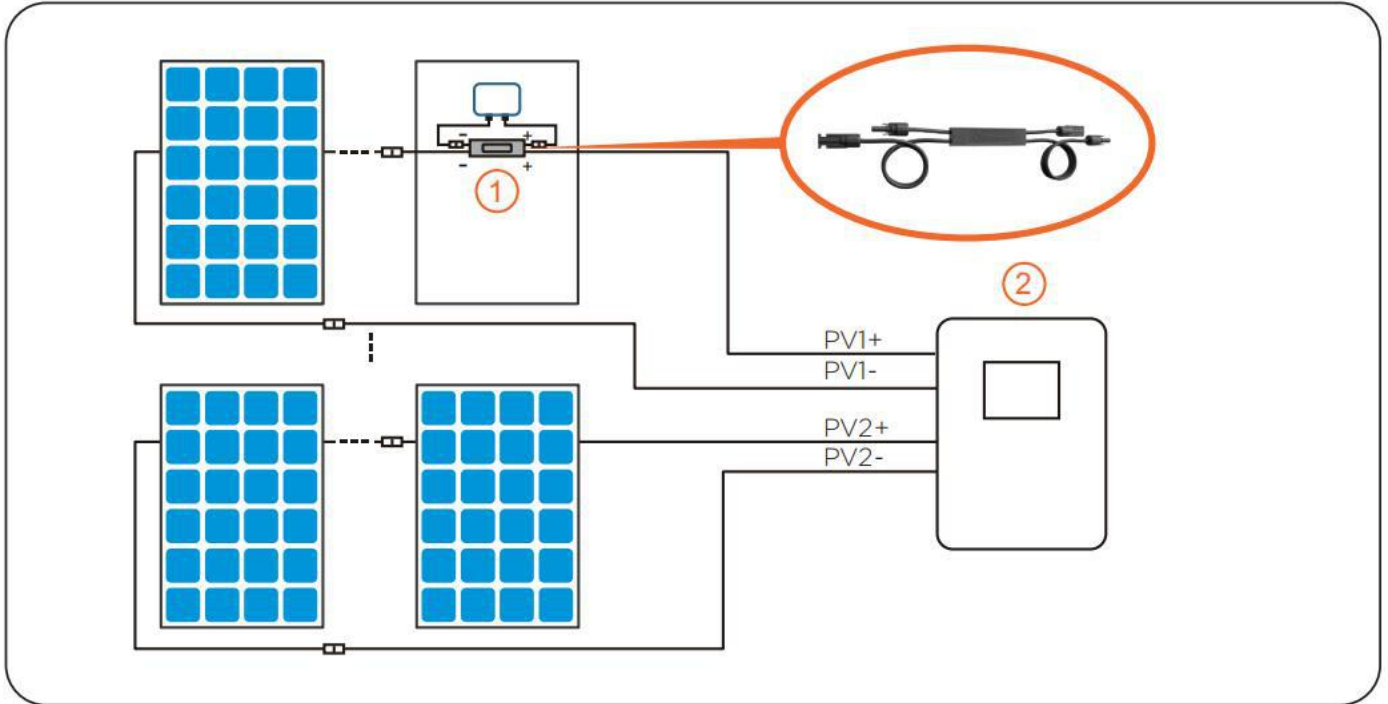

① RSD-S-PLC

② Inverter*

* Inverter in diagram includes an integrated SunSpec-certified Rapid Shutdown Transmitter.

RSD-S-PLC INSTALLATION

INSTALLATION NOTES

Installation **MUST** comply with local regulations and technical rules:

- ① Perform all electrical installations in accordance with local codes.
- ② Be aware that only qualified professionals should install and/or replace the RSD-S-PLC.
- ③ Before installing or using an RSD-S-PLC, please read all instructions and warnings in the technical documents and on the inverter system itself as well as on the PV array.
- ④ Be aware that installation of this equipment includes the risk of electric shock.
- ⑤ Do not touch any live parts in the system, including the PV array, when the system has been connected to the electrical grid.
- ⑥ Ensure the PV module and inverter have been disconnected before installing an RSD-S-PLC.
- ⑦ Do not attaching negative power wires in the homerun on any RSD devices or connectors.

- ① Be sure to verify the voltage and current specifications of your PV module match with those of the RSD-S-PLC.
- ② The maximum open circuit voltage of the PV module must not exceed the specified maximum input voltage of the APsmart RSD-S-PLC.

Additional installation components from APsmart

- DC extension cable (sold separately)

Required parts and tools to complete the installation

In addition to your PV array and its associated hardware, you will need a torque wrench and a Phillips screwdriver.

RSD-S-PLC INSTALLATION

Step 1: Install the RSD-S-PLC.

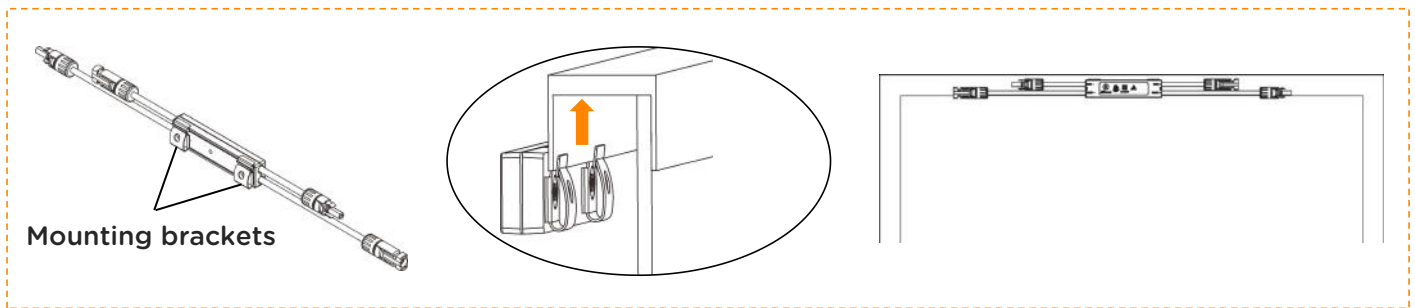

NOTE: Do not place the RSD-S-PLC (including DC connectors) where exposed to the sun, rain or snow, even gap between modules. Any surface of the RSD other than the mounting bracket must be at least 15mm away from surrounding objects. In particular, it is forbidden to have DC cables run close to or cover the RSD-S-PLC casing.

Step 2: Connect the input connectors of the RSD-S-PLC to the junction box, the device output DC voltage is within the range of 0.6 to 1v.

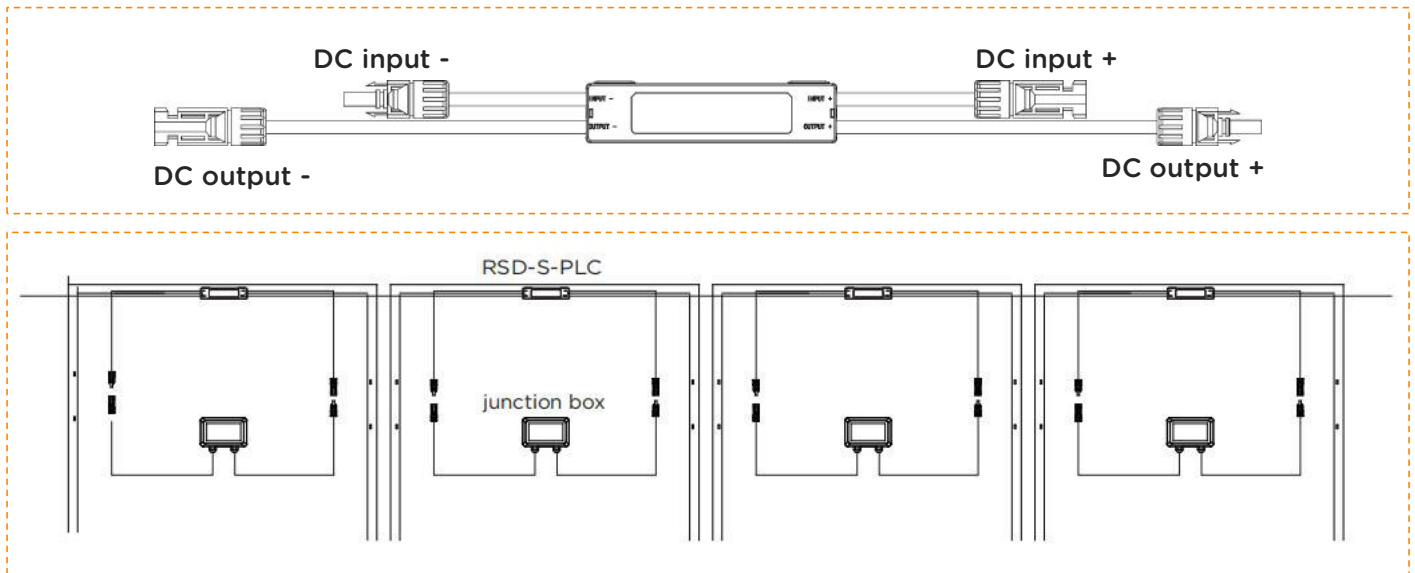

NOTE: Do not short-circuit the RSD-S-PLC output connectors, otherwise it will be damaged.

RSD-S-PLC cable length

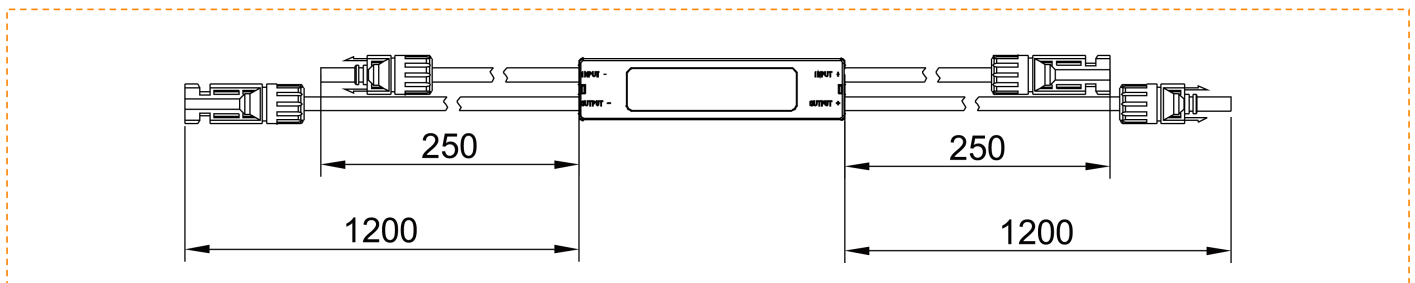

RSD-S-PLC INSTALLATION

NOTE: The output cable length of triad junction box PV module should be no less than 0.9m.

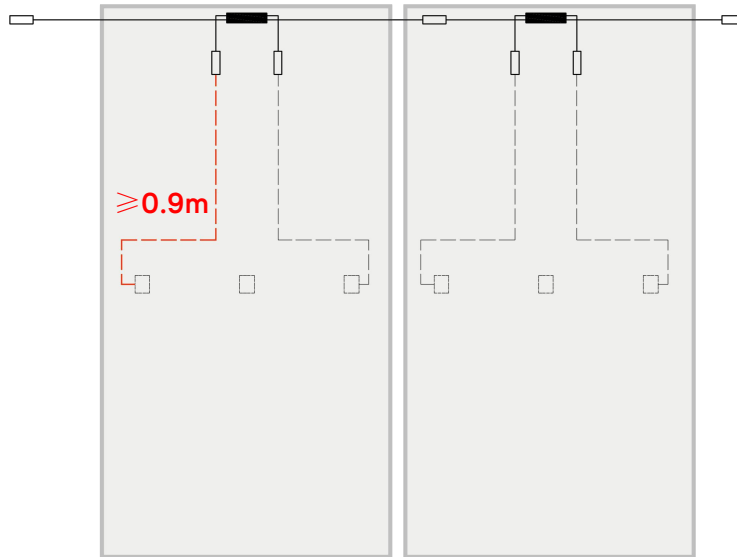

NOTE: The output cable length of integrated junction box PV module should be no less than 0.9m.

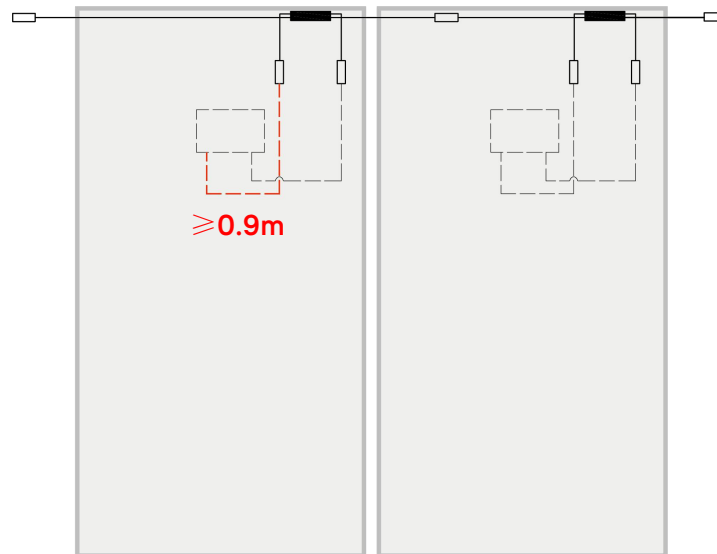

RSD-S-PLC INSTALLATION

NOTE: When installing RSD-S cable, the bending radius of the cable near the casing must be greater than 50 mm.

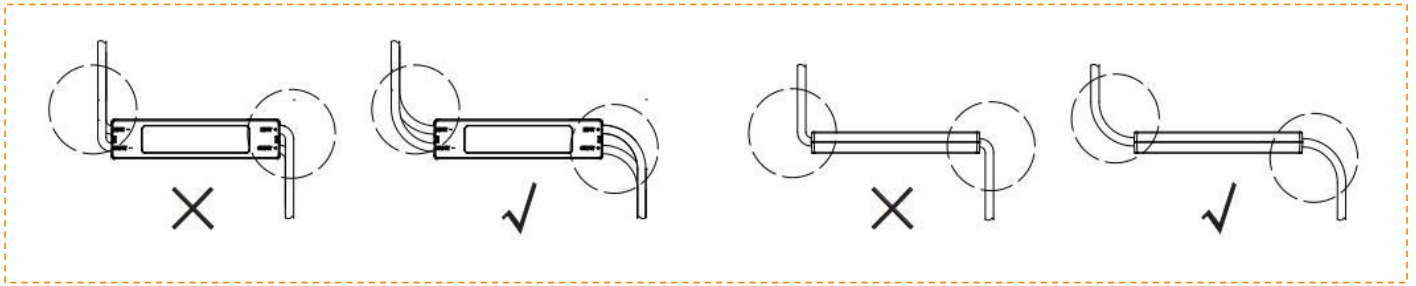

Step 3: Connect the output connectors of the RSD-S-PLC in series to the string, the string open-air DC voltage is within the range of $(0.6 \sim 1v) \times \text{\#RSD-S-PLCs}$. (This range may vary due to different on-site environment.)

NOTE: Do not connect homerun to inverter before finishing all strings connections and tests.

NOTE: Please use the same type of DC connector as the RSD in the system. The RSD damage caused by using different type of DC connector will not be covered by the warranty.

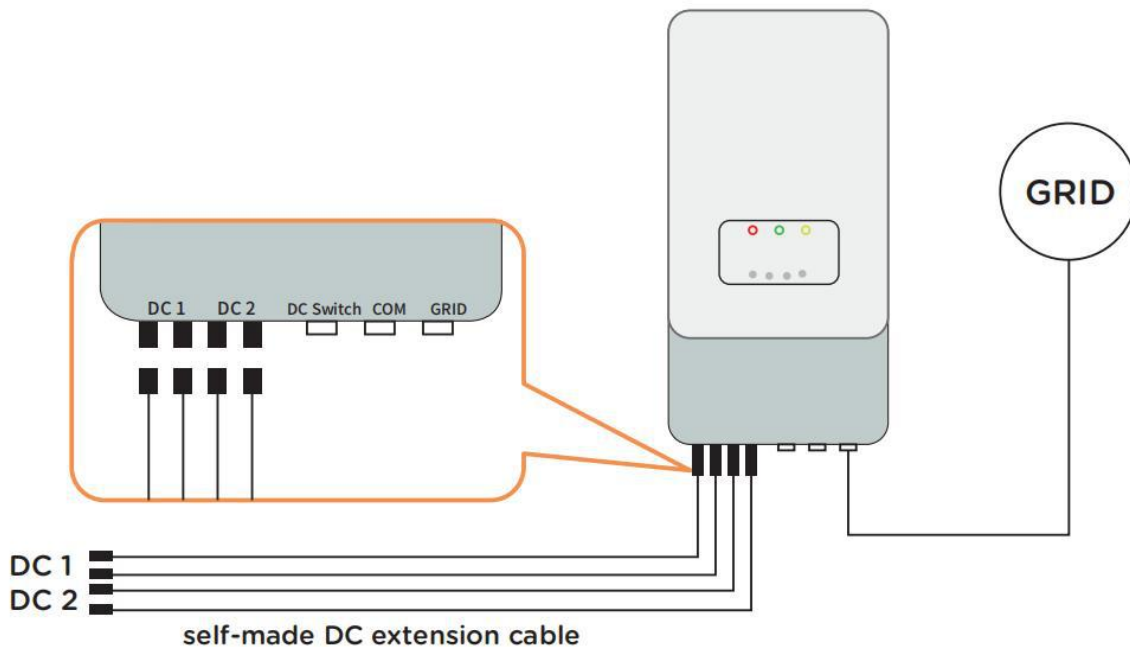

RSD-S-PLC INSTALLATION

NOTE:

- ① When there are two strings of photovoltaic modules connected in parallel under the same MPPT, the photovoltaic strings connected to the same MPPT need to use the same type and same quantity of photovoltaic components. Additionally, the orientation and tilt angle of all photovoltaic components must be the same.
- ② In order to achieve rapid shutdown function, each photovoltaic module in the RSD system must match its corresponding RSD. 'Installing only a portion of them' is not allowed.
- ③ When RSD and modules are installed close to the roof (e.g., on a color steel tile roof), it is recommended to have a spacing of $>20\text{cm}$ between the modules, a ventilation area height of $\geq 10\text{cm}$, and no obstructions.
- ④ To ensure reliable communication, the DC cables must be separated from the AC cables, with a distance greater than 10cm .
- ⑤ To ensure reliable communication and reduce EMC interference, it is required that the positive and negative RSD cables be close to each other along with companion cables (minimizing the distance, initially placing the positive and negative conductors of the same string of wires in the same cable tray), as shown in the multiple string installation scenario in the diagram below.

RSD installation location requirements:



RSD-S-PLC INSTALLATION

Recommended wiring method:

Always place the positive and negative terminals of the same string of wires in the same cable tray and minimize the distance between them as much as possible.

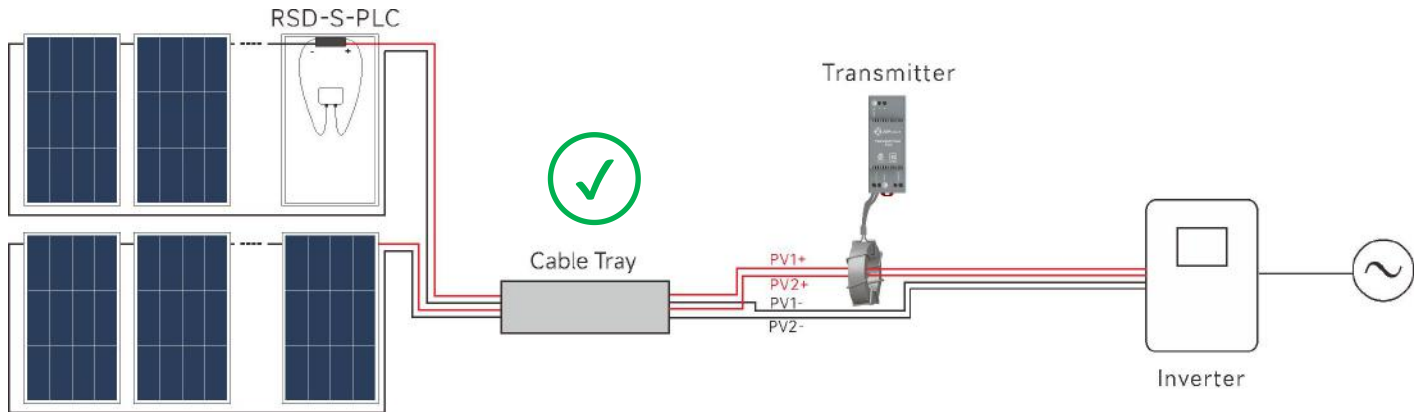

Prohibited wiring method:

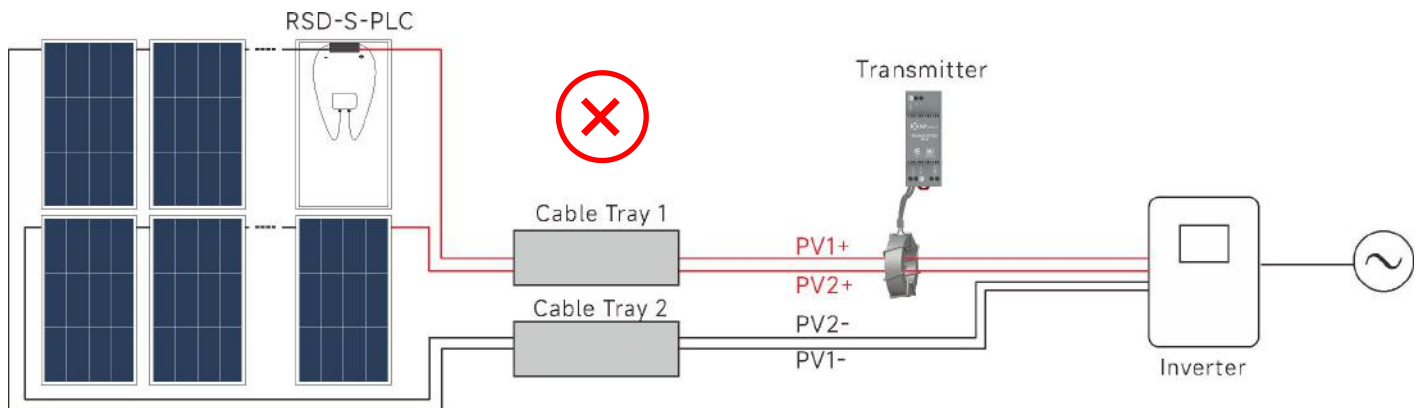

RSD-S-PLC INSTALLATION

How to achieve the independent shutdown of a single system in a multi-system state.

Sharing the same cable tray among multiple systems is the direct cause of signal interference. To achieve independent shutdown, it is necessary to ensure that each system has independent routing, and the distance between cable trays should be maintained at least 20cm apart.

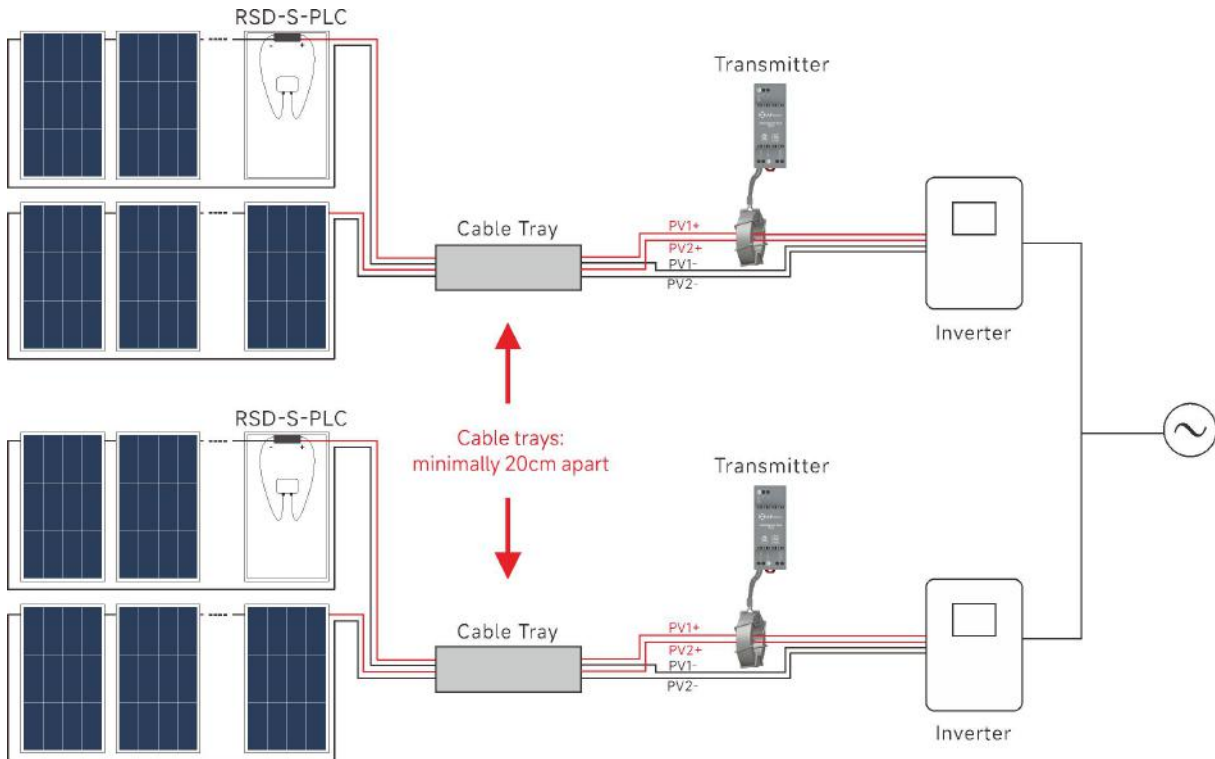

Do not place wires from different inverters in the same cable tray. Asynchronous signals may cause crosstalk and lead to abnormal system behavior.

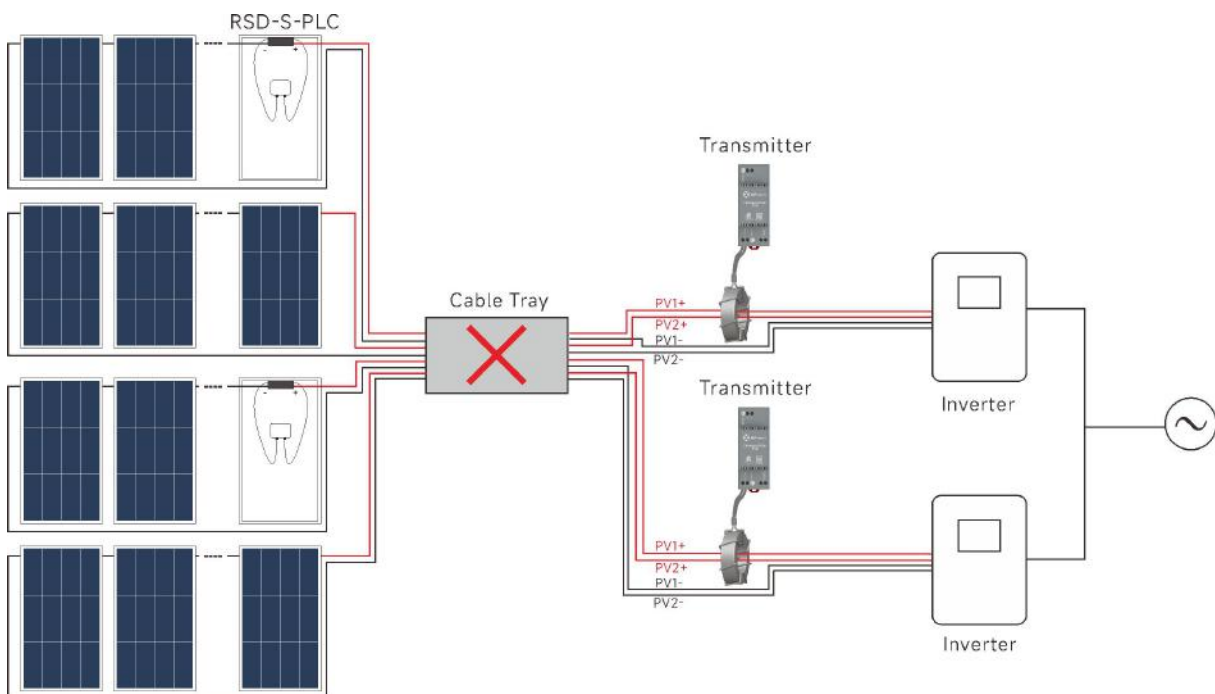

TRANSMITTER-PLC INSTALLATION

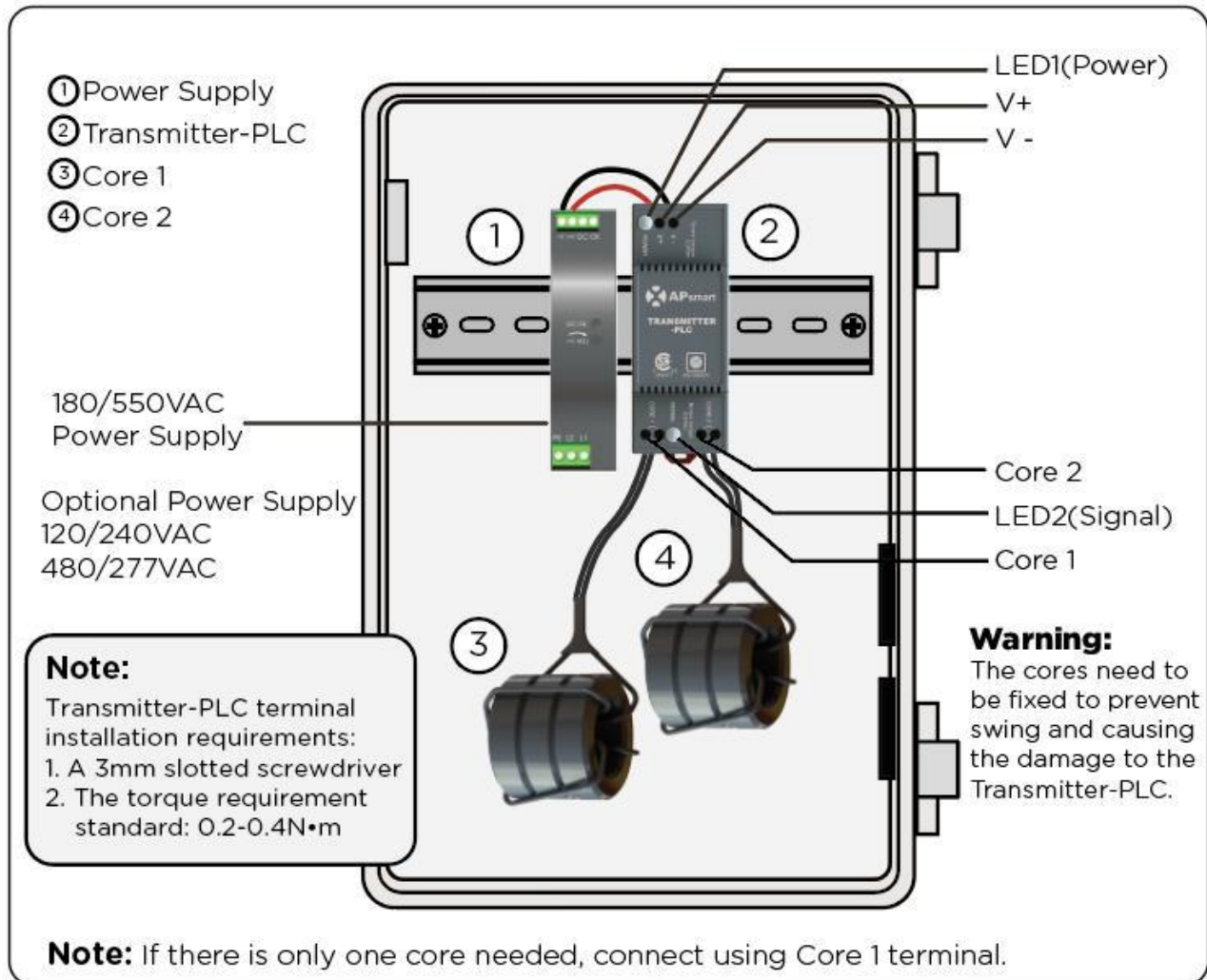

WARNING: The cores need to be fixed to prevent swing and causing the damage to the Transmitter-PLC.

The power supply of the Transmitter-PLC and the inverter must be on same AC branch circuit as inverter to meet rapid shutdown requirements.

During operation, the Power LED should be lit and the Signal LED should be blinking. If the Transmitter-PLC fails to work, the Signal LED will not be blinking. If the Power LED is also not lit, check the power supply first.

NOTE: Install the RSD-S-PLC before powering the Transmitter-PLC.

- Mount Transmitter-PLC and power supply on DIN rail
- Connect DC leads from power supply to Transmitter-PLC
- Connect single/dual core(Core 1 and Core 2) to Transmitter-PLC

Place rapid shutdown system label no more than 1m (3ft) from Transmitter-PLC or AC disconnect if not at same location.

TRANSMITTER-PLC INSTALLATION

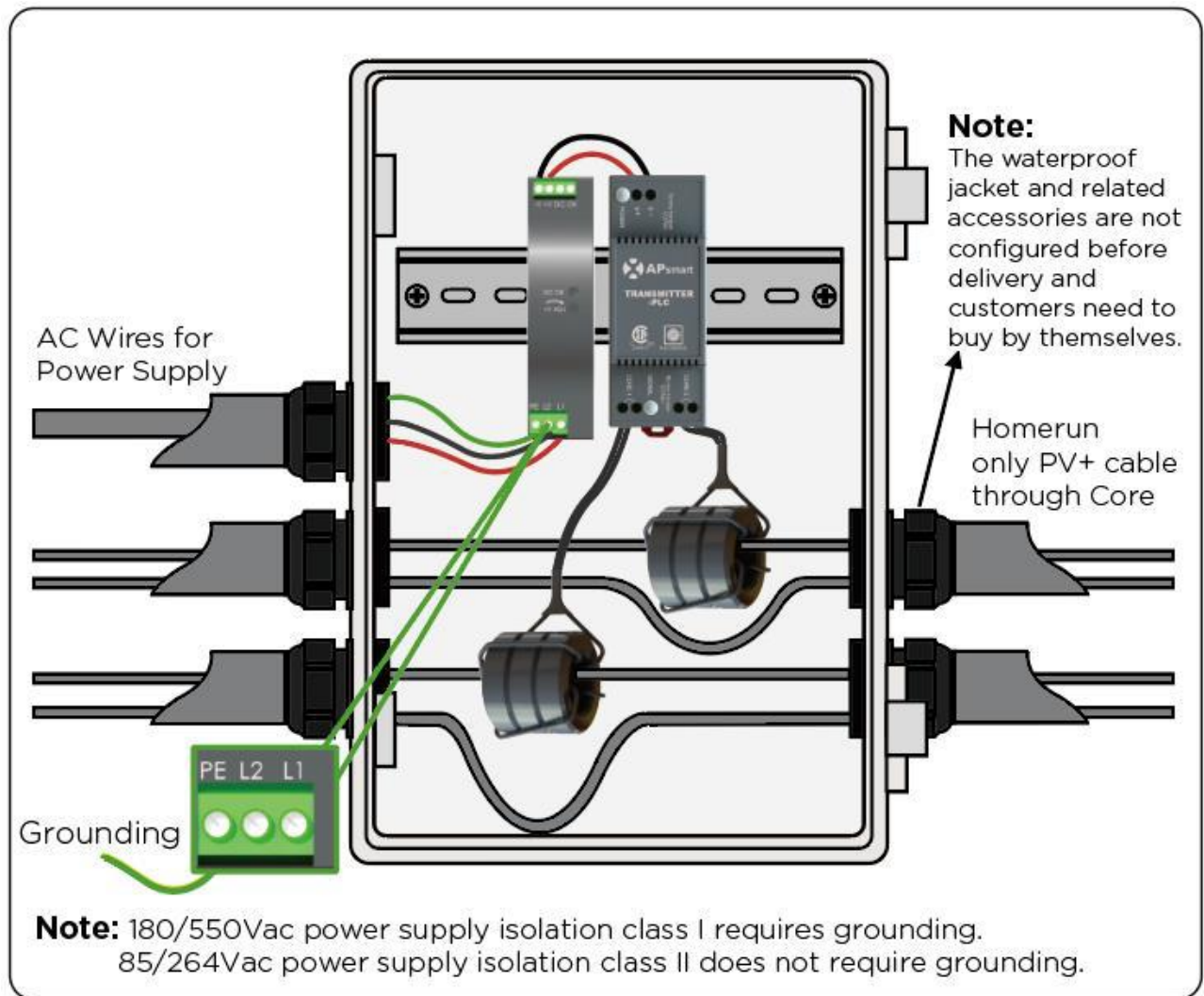

NOTE: Install the RSD-S-PLC before powering the Transmitter-PLC.

NOTE: The waterproof jacket and related accessories are not configured before delivery and customers need to buy by themselves.

- Pass either positive or negative cables through cores (either both positive cables or both negative cables. Do not use one positive and one negative cable.)
- Connect wires to AC side of power supply

Max number of Strings Per Core :

DC cable Diameter(without connector)	Φ 5.9mm	Φ 6.35mm	Φ 7mm	Φ 8.6mm
25mm Core	≤15	≤15	≤14	≤10
11mm Core	≤6	≤5	≤4	≤2

Max string length: 30 modules

Max current per core: 160A(25mm)/75A(11mm)

Max cable length from inverter(+) to inverter(-) : 800m

TRANSMITTER-PLC INSTALLATION

Drilling Guide for .75" Conduit

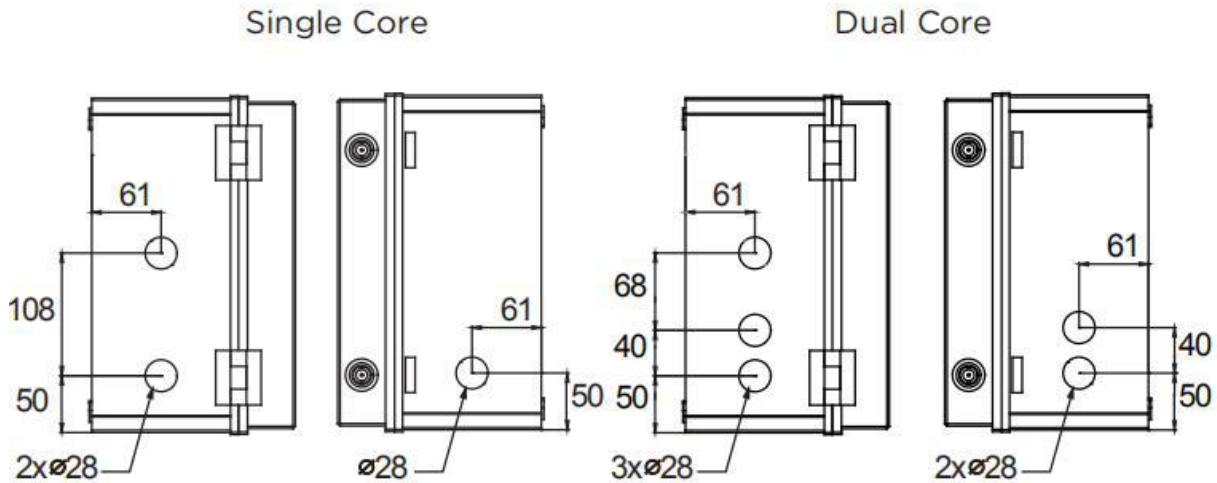

Drilling Guide for 1" Conduit

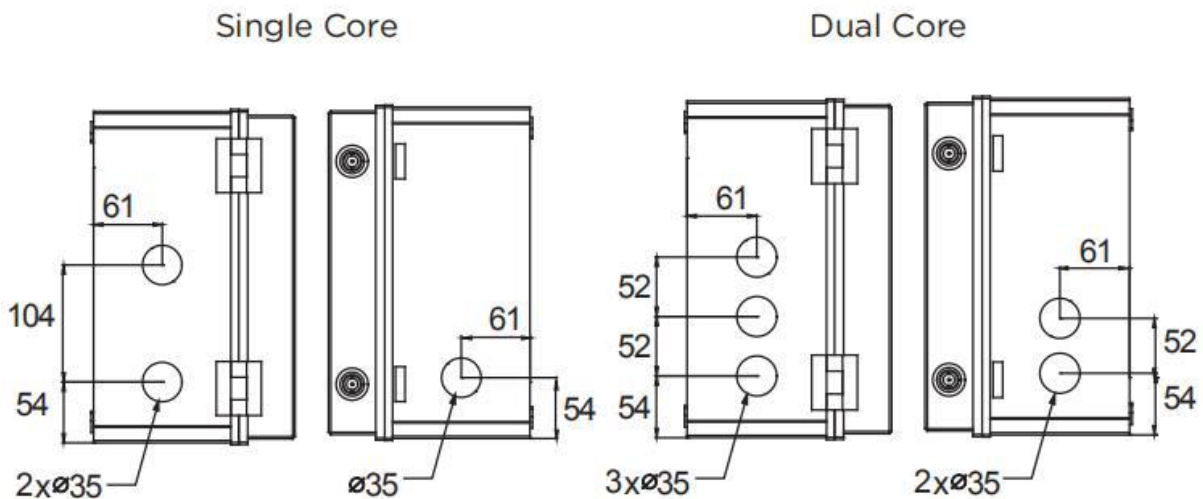

NOTE: The Outdoor Kit was not punched before delivery and customer need to make it themselves according to the actual situation. The figure is only for reference.

TECHNICAL DATA—RSD-S-PLC

Model

RSD-S-PLC

Input Data (DC)

Input Operating Voltage Range	8-80V
Maximum Cont. Input Current (Imax)	15A
Maximum Short Circuit Current (Isc)	25A

Output Data (DC)

Output Operating Voltage Range	8-80V
Maximum System Voltage	1000V/1500V
Maximum Series Fuse Rating	30A

Mechanical Data

Operating Ambient Temperature Range	-40 °F to +185 °F (-40 °C to + 85 °C)
Dimensions (without cable & connectors)	5.5" x 1.3" x 0.7"(140 mm x 32 mm x 18 mm)
Cable Length	Input 250mm/Output 1200mm
Cable Cross Section Size	UL: 12AWG
Connector	Input: Stäubli MC4 PV-KBT4&KST4 or Customize Output: APsystems specified or Customized
Enclosure Rating	NEMA Type 6P/IP68
Protection Temperature	100°C

Features & Compliance

Communication	PLC
Safety Compliance	NEC 2017, 2020&2023 (690.12); UL1741; CSA C22.2 No. 330-17; IEC/EN62109-1; 2PFG2305
EMC Compliance	FCC Part15; ICES-003;IEC/EN61000-6-1/-2/-3/-4

TECHNICAL DATA—TRANSMITTER-PLC

Model

Transmitter-PLC

Main electrical data

Input Voltage	12VDC
Input Current	0.8A
Communication	PLC

Power Supply

Residential (optional)	85-264VAC Input, 12VDC Output, 90 mm x 17.5 mm x 58.4 mm
Commercial (optional)	180-550VAC Input, 12VDC Output, 125.2 mm x 32 mm x 102 mm

Core data

	25mm Core	11mm Core
Max. Current	320A (160A*2)	150A (75A*2)
Max. System Voltage	1500VDC	1500VDC
Internal Opening for Wires/Outside Dimensions	~25mm/64mm	~11mm/42mm
Max. Supported PV Modules per String	30 modules	30 modules

Number Of Strings Per Core

DC Cable Diameter(without connector)	Φ5.9mm	Φ6.35mm	Φ7mm	Φ8.6mm
25mm Core	≤15	≤15	≤14	≤10
11mm Core	≤6	≤5	≤4	≤2

Environmental

Temperature	-40°C ~ +100°C
-------------	----------------

Structure data

Dimensions (W x H x D)	90 mm x 35 mm x 40 mm
Enclosure Environmental Rating	IP30

Features & Compliance

Safety Compliance	NEC 2017, 2020&2023 (690.12); UL1741; CSA C22.2 No. 330-17
EMC Compliance	FCC Part15; ICES-003

TECHNICAL DATA — TRANSMITTER-PLC-OUTDOOR KIT

Model

Transmitter-PLC-Outdoor Kit

Main electrical data

Input Voltage	12VDC
Input Current	0.8A
Communication	PLC

Power Supply

Residential (optional)	85-264VAC Input, 12VDC Output, 90 mm x 17.5 mm x 58.4 mm
Commercial (optional)	180-550VAC Input, 12VDC Output, 125.2 mm x 32 mm x 102 mm

Core data

Max.Current	320A (160A*2)
Max. System Voltage	1500VDC
Internal Opening for Wires/Outside Dimensions	-25mm/64mm
Max. Supported PV Modules per String	30 modules

Number Of Strings Per Core

DC Cable Diameter(without connector)	Φ5.9mm	Φ6.35mm	Φ7mm	Φ8.6mm
25mm Core	≤15	≤15	≤14	≤10

Environmental

Temperature	-40°C ~ +60°C
-------------	---------------

Structure data

Dimensions (W x H x D)	198.5 mm x 298 mm x 179 mm
Enclosure Environmental Rating	IP30

Features & Compliance

Safety Compliance	NEC 2017, 2020&2023 (690.12); UL1741; CSA C22.2 No. 330-17
EMC Compliance	FCC Part15; ICES-003

ORDERING INFORMATION

Transmitter-PLC

406010	25mm Enhanced Single Core Transmitter-PLC (no power supply), core line length 300mm
406011	25mm Enhanced Dual Core Transmitter-PLC (no power supply), core line length 300mm
406012	25mm Enhanced Dual Core Transmitter-PLC (no power supply), core line length 400mm
406013	25mm Enhanced Dual Core Transmitter-PLC (no power supply), core line length 350mm
406002	11mm Dual Core Transmitter-PLC (no power supply)
406003	11mm Single Core Transmitter-PLC (no power supply)
408004	Single Core Transmitter-PLC Outdoor Kit, 180-550VAC Power Supply
408005	Dual Core Transmitter-PLC Outdoor Kit, 180-550VAC Power Supply
408006	Single Core Transmitter-PLC Outdoor Kit, 85-264VAC Power Supply
408007	Dual Core Transmitter-PLC Outdoor Kit, 85-264VAC Power Supply
408010	Single Core Transmitter-PLC-Outdoor Kit, 180-550VAC Power Supply, Emergency button
408011	Dual Core Transmitter-PLC-Outdoor Kit, 180-550VAC Power Supply, Emergency button
408012	Single Core Transmitter-PLC-Outdoor Kit, 85-264VAC Power Supply, Emergency button
408013	Dual Core Transmitter-PLC-Outdoor Kit, 85-264VAC Power Supply, Emergency button

RSD-S-PLC

415002	1500V UL, 1.2m cable, Stäubli MC4 PV-KBT4&KST4
4150XX*	1500V UL, 15A, 1.2m cable, Customized connector

**please see the RSD Series Ordering Information*



8627 N Mopac Expy, Suite 150, Austin, TX 78759 | +1-737-218-8486 |
+1-866-374-8538 | support@APsmartGlobal.com | APsmartGlobal.com